



**Digital Video Broadcasting (DVB);
Modulator Interface (T2-MI) for a second
generation digital terrestrial television
broadcasting system (DVB-T2)**

DVB Document A136r2

June 2009

Contents

Intellectual Property Rights	5
Foreword	5
1 Scope	6
2 References	6
2.1 Normative references	7
2.2 Informative references	7
3 Definitions, symbols and abbreviations	8
3.1 Definitions	8
3.2 Symbols	9
3.3 Abbreviations	9
4 General description	11
4.1 System overview	11
4.2 System architecture	11
4.3 Protocol stack	12
5 T2-MI packets	13
5.1 T2-MI packet definition	13
5.2 T2-MI payload definitions	14
5.2.1 Baseband Frame	14
5.2.2 Auxiliary stream I/Q data	15
5.2.3 L1-current T2-MI packets	16
5.2.4 L1-future	17
5.2.5 DVB-T2 timestamp	18
5.2.5.1 Null timestamp	19
5.2.6 Individual addressing	19
5.2.6.1 Existing addressing functions	20
5.2.6.2 Addressing functions specific to DVB-T2	20
5.2.6.2.1 PAPR function	20
5.2.6.2.2 MISO group function	21
5.2.7 FEF part: Null	21
5.2.8 FEF part: I/Q data	22
5.3 Generation of L1 signalling from the T2-MI packets	23
5.4 Transmission order of T2-MI packets	23
5.5 Timing of T2-MI packet transmission	24
6 Transport of T2-MI packets	24
6.1 Encapsulation of T2-MI packets in MPEG-2 TS	24
6.1.1 Description	25
6.2 Encapsulation of MPEG-2 TS in IP packets	25
6.2.1 Setup Information	26
6.2.2 Transport Protocols	26
6.2.3 Session Initiation and Control	27
6.2.4 Network Requirements	27
Annex A (normative): Calculation of the CRC word	28
Annex B (normative): T2 Modulator Information Packet (T2-MIP)	29
B.1 Use of the T2-MIP for over the air synchronization	29
B.2 T2-MIP Definition	30
B.2.1 Field description	30
B.2.2 Transmission of the T2-MIP over DVB-T2	33
Annex C (informative): Local Content Insertion	34

Annex D (informative): MISO Management	35
Annex E (informative): T2-MI overhead	36
E.1 Encapsulation of T2 data within T2-MI packets.....	36
E.2 Transport of T2-MI packets.....	36
E.2.1 T2-MI packets over MPEG-2 TS.....	36
E.2.1.1 FEC overhead for an ASI link.....	36
E.2.2 T2-MI packets over MPEG-2 TS to IP.....	36
E.2.2.1 FEC overhead.....	37
E.3 Summary of the overheads associated with T2-MI.....	37
Annex F (informative): DVB-T2 Timestamps	38
F.1 Relationships.....	38
F.2 Rationale.....	38
History.....	39
<i>History box entries</i>	39

Intellectual Property Rights

IPRs essential or potentially essential to the present document may have been declared to ETSI. The information pertaining to these essential IPRs, if any, is publicly available for **ETSI members and non-members**, and can be found in ETSI SR 000 314: "*Intellectual Property Rights (IPRs); Essential, or potentially Essential, IPRs notified to ETSI in respect of ETSI standards*", which is available from the ETSI Secretariat. Latest updates are available on the ETSI Web server (<http://webapp.etsi.org/IPR/home.asp>).

Pursuant to the ETSI IPR Policy, no investigation, including IPR searches, has been carried out by ETSI. No guarantee can be given as to the existence of other IPRs not referenced in ETSI SR 000 314 (or the updates on the ETSI Web server) which are, or may be, or may become, essential to the present document.

Foreword

This Technical Specification (TS) has been produced by ETSI Technical Committee {ETSI Technical Committee|ETSI Project|<other>} <long techbody> (<short techbody>).

1 Scope

The present document defines the interface to a modulator for a second generation terrestrial television system (DVB-T2). This document also describes a mechanism to allow the operation of over the air regenerative repeaters in SFN or non-SFN networks.

2 References

References are either specific (identified by date of publication and/or edition number or version number) or non-specific.

- For a specific reference, subsequent revisions do not apply.
- Non-specific reference may be made only to a complete document or a part thereof and only in the following cases:
 - if it is accepted that it will be possible to use all future changes of the referenced document for the purposes of the referring document;
 - for informative references.

Referenced documents which are not found to be publicly available in the expected location might be found at <http://docbox.etsi.org/Reference>.

For online referenced documents, information sufficient to identify and locate the source shall be provided. Preferably, the primary source of the referenced document should be cited, in order to ensure traceability. Furthermore, the reference should, as far as possible, remain valid for the expected life of the document. The reference shall include the method of access to the referenced document and the full network address, with the same punctuation and use of upper case and lower case letters.

NOTE: While any hyperlinks included in this clause were valid at the time of publication ETSI cannot guarantee their long term validity.

2.1 Normative references

The following referenced documents are indispensable for the application of the present document. For dated references, only the edition cited applies. For non-specific references, the latest edition of the referenced document (including any amendments) applies.

- [1] ETSI EN 302 755: "Digital Video Broadcasting (DVB); Frame structure channel coding and modulation for a second generation digital terrestrial television broadcasting system (DVB-T2)".
- [2] ETSI TS 102 606: "Digital Video Broadcasting (DVB); Generic Stream Encapsulation (GSE) Protocol".
- [3] ETSI TS 101 191: "Digital Video Broadcasting (DVB); DVB mega-frame for Single Frequency Network (SFN) synchronization".
- [4] ETSI EN 301 192: "Digital Video Broadcasting (DVB); DVB specification for data broadcasting".
- [5] ETSI TS 102 034: "Transport of MPEG-2 TS based DVB services over IP Based networks".
- [6] IETF RFC 3550: "RTP: A Transport Protocol for Real-Time Applications".
- [7] ISO/IEC 13818-1: "Information technology - Generic coding of moving pictures and associated audio information: Systems".
- [8] ETSI EN 300 468: "Digital Video Broadcasting (DVB); Specification for Service Information (SI) in DVB systems".

2.2 Informative references

The following referenced documents are not essential to the use of the ETSI deliverable but they assist the user with regard to a particular subject area. For non-specific references, the latest version of the referenced document (including any amendments) applies.

- [i.1] ETSI TR 102 831: "Digital Video Broadcasting (DVB); Implementation guidelines for a second generation digital terrestrial television broadcasting system (DVB-T2)".
- [i.2] EN 50083-9: "Cabled distribution systems for television, sound and interactive multimedia signals; Part 9: Interfaces for CATV/SMATV headends and similar professional equipment for DVB/MPEG-2 transport streams" (DVB Blue Book A010)".
- [i.3] DVB Blue Book A115

3 Definitions, symbols and abbreviations

3.1 Definitions

For the purposes of the present document, the terms and definitions given in [i.1] and the following apply:

Auxiliary Stream: A sequence of cells carrying data of as yet undefined modulation and coding, which may be used for future extensions or as required by broadcasters or network operators.

Common PLP: PLP having one slice per T2 frame, transmitted just after the L1 signalling, which may contain data shared by multiple PLPs.

Configurable L1-signalling: L1 signalling consisting of parameters which remain the same for the duration of one super-frame.

Coordinated Universal Time (literally Universel Temps Coordonné) (UTC): time format counting in standard SI seconds with periodic adjustments made by the addition (or removal) of leap seconds to keep the difference between UTC and Astronomical Time less than $\pm 0,9$ s.

Data PLP: A PLP of Type 1 or Type 2.

Dynamic L1-signalling: L1 signalling consisting of parameters which may change from one T2-frame to the next.

Elementary Period: Time period which depends on the system bandwidth and is used to define the other time periods in the T2 system.

FEC Block: A set of N_{cells} OFDM cells carrying all the bits of one LDPC FECFRAME.

FECFRAME: The set of N_{ldpc} (16200 or 64800) bits from one LDPC encoding operation.

FEF part: The part of the super-frame between two T2-frames which may contain (FEFs).

FFT size: The nominal FFT size used for a particular mode, equal to the active symbol period T_s expressed in cycles of the elementary period T .

Global Position System (GPS): A constellation of satellites providing accurate time and position information to receivers.

GPS Time: Time signal broadcast by the GPS satellites using an epoch of January 6th 1980 with no leap seconds and a 'week number' (actually a modulo-604 800 seconds number) that wraps every 1 024 weeks (approximately 19,7 years).

Interleaving frame: The unit over which dynamic capacity allocation for a particular PLP is carried out, made up of a integer, dynamically varying number of FEC blocks and having a fixed relationship to the T2-frames. The Interleaving frame may be mapped directly to one T2-frame or may be mapped to multiple T2-frames. It may contain one or more TI-blocks.

International Atomic Time (literally Temps Atomique International) (TAI): Time format counting in standard SI seconds.

L1 pre-signalling: Signalling carried in the P2 symbols having a fixed size, coding and modulation, including basic information about the T2 system as well as information needed to decode the L1 post-signalling. L1 pre-signalling remains the same for the duration of a super-frame.

L1-post-signalling: Signalling carried in the P2 symbol carrying more detailed L1 information about the T2 system and the PLPs.

MISO group: The group (1 or 2) to which a particular transmitter in a MISO network belongs, determining the type of processing which is performed to the data cells and the pilots. Signals from transmitters in different groups will combine in an optimal manner at the receiver.

Modified Julian Date (MJD): Date format based on the number of days since midnight GMT on 17th November 1858 AD.

P1 signalling: Signalling carried by the P1 symbol and used to identify the basic mode of the DVB-T2 symbol.

Physical Layer Pipe (PLP): physical layer TDM channel that is carried by the specified sub-slices.

NOTE: A PLP may carry one or multiple services.

PLP_ID: This 8-bit field uniquely identifies a PLP within the T2 system, identified with the T2_system_id. The same PLP_ID may occur in one or more frames of the superframe.

Relay (transmitter): A transmitter in a network that re-transmits a signal received off-air, either by simple frequency transposition or by regenerating the signal.

T2 frame: Fixed physical layer TDM frame that is further divided into variable size sub-slices. T2 frame starts with one P1 and one or multiple P2 symbols.

T2 Super-frame: A set of T2 frames consisting of a particular number of consecutive T2 frames. A superframe may in addition include FEF parts.

T2 system: second generation terrestrial broadcast system whose input is one or more TS or GSE streams and whose output is an RF signal.

NOTE: The T2 system:

- means an entity where one or more PLPs are carried, in a particular way, within a DVB-T2 signal on one or more frequencies.
- is unique within the T2 network and it is identified with T2_system_id. Two T2 systems with the same T2_system_id and network_id have identical physical layer structure and configuration, except for the cell_id which may differ.
- is transparent to the data that it carries (including transport streams and services).

T2_SYSTEM_ID: This 16-bit field identifies uniquely the T2 system within the T2 network.

Time interleaving block (TI-block): A set of cells within which time interleaving is carried out, corresponding to one use of the time interleaver memory.

Type 1 PLP: PLP having one slice per T2 frame, transmitted before any Type 2 PLPs.

Type 2 PLP: PLP having two or more sub-slices per T2 frame, transmitted after any Type 1 PLPs.

T2-Gateway: A device producing T2-MI at its output, incorporating the functionality of the Basic T2-Gateway and, optionally, additional processing such as re-multiplexing.

$\lceil x \rceil$: round towards plus infinity: the most negative integer greater than or equal to x

3.2 Symbols

For the purposes of the present document, the symbols given in [i.1] and the following apply:

N_x	The value N is expressed in radix x . The radix of x shall be decimal, thus $2A_{16}$ is the hexadecimal representation of the decimal number 42.
T	Elementary time period for the bandwidth in use

3.3 Abbreviations

For the purposes of the present document, the abbreviations given in [i.1] and the following apply:

ASI	Asynchronous Serial Interface
bflbf	Bit-field, left bit first
bflbfzpb	Bit-field, left bit first, zero padded after the last bit to a multiple of 8 bits
FEC	Forward Error Correction

GPS	Global Positioning System
LoCI	Local Content Inserter
MJD	Modified Julian Date
PLP	Physical Layer Pipe
RF	Radio Frequency
RFU	Reserved for Future Use
rpchof	Remainder Polynomial Coefficients, Highest Order First
rms	root mean square
T2	DVB-T2
T2-MI	DVB-T2 Modulator Interface
T2-MIP	DVB-T2 Modulator Information Packet
TAI	International Atomic Time (literally Temps Atomique International)
TFS	Time Frequency Slicing
TS	Transport Stream
uimsbf	Unsigned integer, most significant bit first
UTC	Coordinated Universal Time (literally Universel Temps Coordonné)

4 General description

4.1 System overview

The DVB-T2 specification [1] enables service-specific robustness to be achieved through the use of Physical Layer Pipes (PLPs). The allocation of data to each PLP is not however prescriptive and the T2 specification merely states that certain constraints must be met.

To enable Single Frequency Network (SFN) operation, decisions on allocation and scheduling are taken once in a T2-Gateway, the results of which are distributed in such a format that each modulator in the network can unambiguously create an identical on-air signal. The DVB-T2 Modulator Interface (T2-MI) defines this format and allows reliable networks of transmitters (in both MFN and SFN configurations) to be constructed. In addition it supports the use of regenerative, off-air repeaters to feed further MFNs and SFNs.

More information regarding the generation of T2-MI in a T2-gateway and its use by a modulator can be found in [i.1].

4.2 System architecture

The block diagram of a typical DVB-T2 end-to-end chain for Transport Stream input is shown in Figure 1. The T2-MI is shown as “Interface B” at the output of the T2-Gateway.

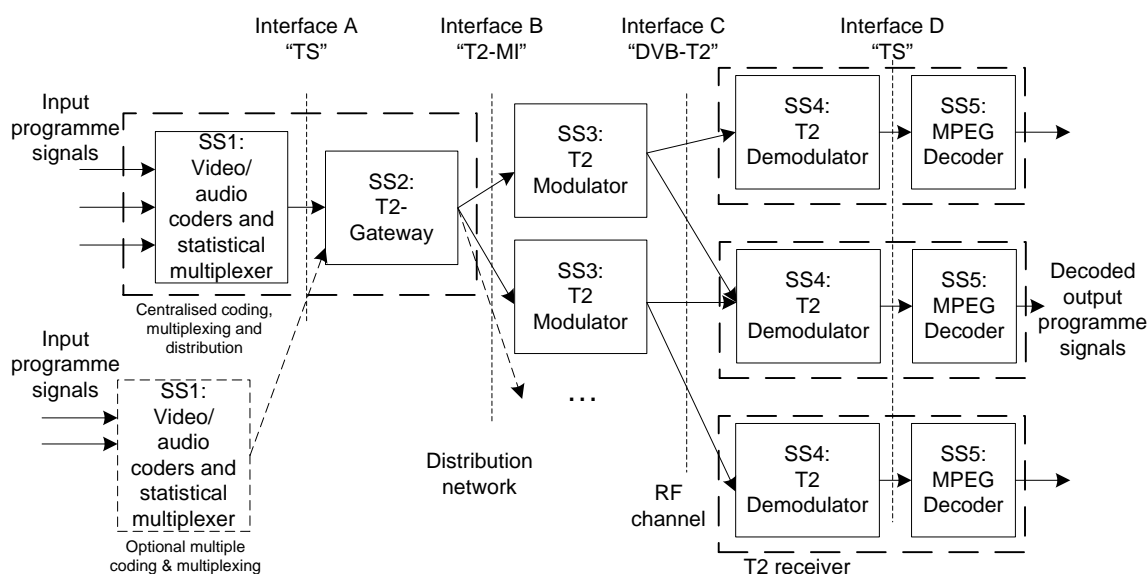

Figure 1: Block diagram of a typical DVB-T2 chain

4.3 Protocol stack

Figure 2 shows the T2-MI protocol stack.

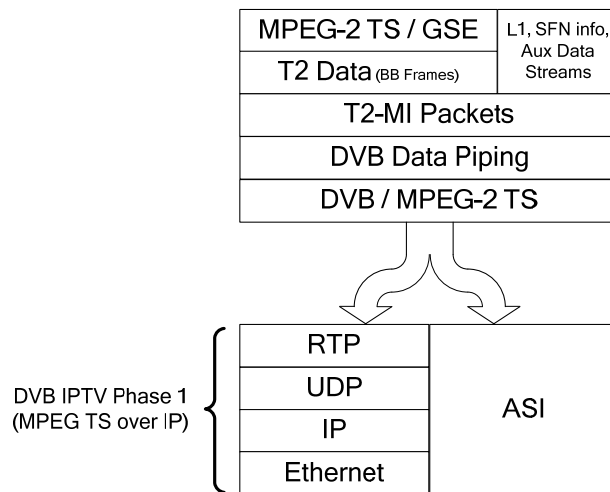

Figure 2: The T2-MI protocol stack

The DVB-T2 Modulator Interface (T2-MI) carries the DVB-T2 system inputs, MPEG-2 TS and/or Generic Streams, encapsulated within DVB-T2 Baseband Frames [1].

In addition the T2-MI also carries other data including, but not limited to:

- L1 signalling data to enable the construction of T2 frames by the modulator,
- IQ vector data for any auxiliary streams,
- DVB-T2 timestamp (for synchronization) and
- Future Extension Frame (FEF) data.

With the exception of the DVB-T2 timestamp, all this information is transmitted as part of the on-air DVB-T2 signal.

The synchronization timestamp data is not transmitted over-air but used by a modulator to define the precise time of emission of the DVB-T2 signal. A special case exists where relay stations forming part of a SFN are fed over air from a master station on a different frequency, since they also require access to the synchronization data (see Annex B).

The T2 data is then packetised into T2-MI packets and encapsulated into DVB / MPEG Transport Stream packets using Data Piping, in accordance with EN 301 192 [4], clause 4.

These standard DVB TS packets are then carried either natively over any standard DVB Transport Stream interface, such as ASI [i.2], or further encapsulated within IP packets in accordance with TS 102 034 [5] for carriage over IP based networks.

5 T2-MI packets

Several different types of T2-related data may be sent over the T2-MI through the use of T2-MI packets.

5.1 T2-MI packet definition

The T2-MI packet format is shown in figure 3.

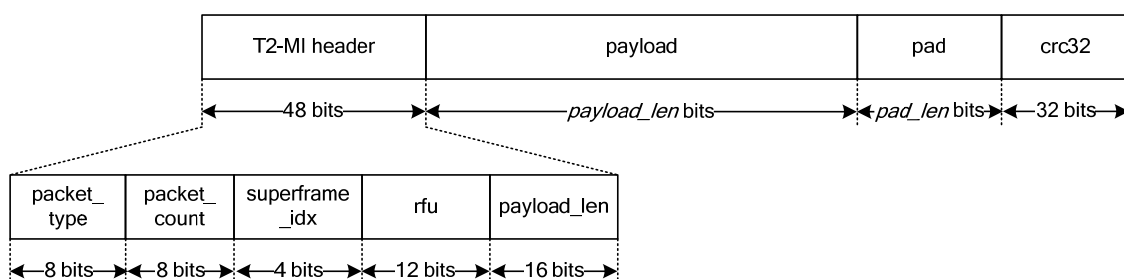

Figure 3: T2-MI packet format

Each T2-MI packet is composed of a 6 byte header, followed by a variable-length payload part plus padding, when required, and a 32-bit CRC tail for error detection.

The T2-MI packet consists of the following fields:

packet_type (8 bits) indicates the type of the payload carried by T2-MI packet. The currently defined values are shown table 1 and their associated formats defined in the following clauses. All other values are reserved for future use (RFU).

Table 1: T2-MI packet types.

T2-MI packet_type	Description
00 ₁₆	Baseband Frame
01 ₁₆	Auxiliary stream I/Q data
10 ₁₆	L1 current
11 ₁₆	L1 future
20 ₁₆	DVB-T2 timestamp
21 ₁₆	Individual addressing
30 ₁₆	FEF part: Null
31 ₁₆	FEF part: I/Q data
all other values	Reserved for future use

packet_count (8 bits) is incremented by one for each T2-MI packet sent, irrespective of payload. There shall be no requirement for the first packet sent to have a specific count value. The counter shall wrap from FF₁₆ to 00₁₆.

superframe_idx (4 bits) shall be constant for all T2-MI packets that carry data pertaining to one T2 superframe. It should be incremented for each subsequent superframe. No implementation shall require this field to have any particular value.

rfu (12 bits) bits reserved for future use and shall all be set to 0₂.

payload_len (16 bits) indicates the payload length in bits

payload (payload_len bits) carries the T2-MI packet payload which will vary depending on the type of the T2-MI packet and is defined in clause 5.2.

pad (pad_len bits) shall be filled with between 0 and 7 bits of padding such that the T2-MI packet is always an integer number of bytes in length, i.e. $payload_len + pad_len$ shall be a multiple of 8. Each padding bit shall have the value 0₂.

crc32 (32 bits) is calculated across all other bits in the packet (both header and payload plus any padding), in accordance with Annex A.

5.2 T2-MI payload definitions

5.2.1 Baseband Frame

T2-MI packets with a **packet_type** of 00_{16} shall carry Baseband Frames, in accordance with [1], clause 5.1.7.

The T2-MI packet payload is shown in figure 4.

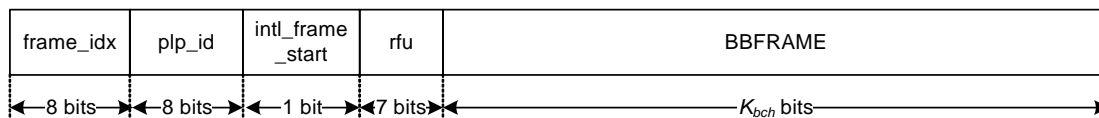

Figure 4: Baseband Frame payload

The fields are defined as follows:

frame_idx (8 bits) indicates the `FRAME_IDX`, as defined in [1], of the first T2 frame to which the Interleaving Frame containing this Baseband Frame is mapped.

plp_id (8 bits) signals the `PLP_ID`, as defined in [1], in which the Baseband Frame is to be carried in the DVB-T2 signal.

intl_frame_start (1 bit) shall be set to 1_2 for the packet containing the first BBFRAME of an interleaving frame for a particular PLP, and '0' for packets carrying the remaining BBFRAMEs (if any).

rfu (7 bits) bits reserved for future use and shall all be set to 0_2 .

BBFRAME (K_{bch} bits) carries the K_{bch} bits of the Baseband Frame (before scrambling) pertaining to a particular PLP, including the PADDING field if used. It shall be encapsulated into exactly one T2-MI packet without additional stuffing. The temporal order of the Baseband Frame bits shall be preserved. If the Baseband Frame PADDING field is used for in-band signalling, the relevant bits of the PADDING field shall be set to '0'. These shall then be replaced by the relevant in-band signalling in the modulator.

5.2.2 Auxiliary stream I/Q data

T2-MI packets with a **packet_type** of 01₁₆ shall carry auxiliary stream data, in accordance with [1], clause 8.3.7.

The T2-MI packet payload is shown in figure 4.

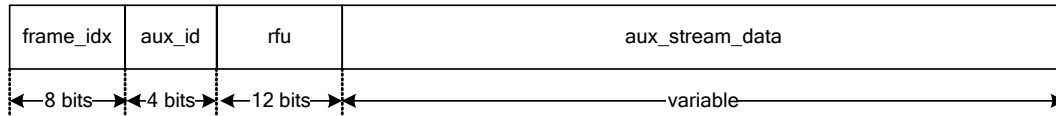

Figure 5: Auxiliary stream payload

frame_idx (8 bits) indicates the FRAME_IDX, as defined in [1], of the T2 frame which carries the auxiliary stream data.

aux_id (4 bits) indicates the particular auxiliary stream to which the data belongs. The auxiliary streams shall be sent in the same order as over the transmitted DVB-T2 signal, starting with aux_id=1₁₆ indicating the first auxiliary stream and with the aux_id being incremented by '1' for each new auxiliary stream. The highest possible value is F₁₆ corresponding to the 15th auxiliary stream. Other values are reserved for future use.

rfu (12 bits) bits reserved for future use.

aux_stream_data (variable bits) carries the data for each auxiliary stream. It shall consist of the complex cell values in order of increasing cell address (as defined in [1]). Each cell value shall be sent as a 12-bit two's complement value I for the real part immediately followed by a 12-bit two's complement value Q for the imaginary part of the complex number. The cell value, $x_{m,l,p}$ for use in clause 8.3.7 of [1] shall be given by:

$$\begin{aligned} \operatorname{Re}(x_{m,l,p}) &= \frac{I}{2^9} \\ \operatorname{Im}(x_{m,l,p}) &= \frac{Q}{2^9} \end{aligned}$$

where I and Q are the 12-bit two's complement values represented as integers in the range -2^{11} to $2^{11}-1$.

NOTE: Given that the rms value of $x_{m,l,p}$ is equal to 1 (as required by [1]), the signal-to-quantisation-noise ratio is approximately 59 dB, which should be adequate for all applications.

The auxiliary stream data field shall be encapsulated into one or more T2-MI packets in the same order as the filling of the OFDM cells in the DVB-T2 signal. No stuffing shall be used.

If more than one T2-MI packet is used for a particular auxiliary stream the payload of T2-MI packets with an unfinished stream must end with a completed cell. The next cell value of that stream will then start at the beginning of the payload of the next T2-MI packet with packet_type 01₁₆ with the same aux_id.

The cell values for auxiliary streams must be the same for all transmitters in a single frequency network when sent over the T2-MI using T2-MI_packet_type 01₁₆. If it is required, however, that the cell values are to differ, as allowed by [1], the auxiliary stream data must be sent to the modulators in an alternative way.

5.2.3 L1-current T2-MI packets

T2-MI packets with a **packet_type** of 10₁₆ shall contain L1 pre- and post-signalling data to be inserted (as described in clause 5.3) into the P2 symbols of the T2-frame indicated by **frame_idx** and describing the same ("current") T2-frame.

The T2-MI packet payload is shown in figure 6.

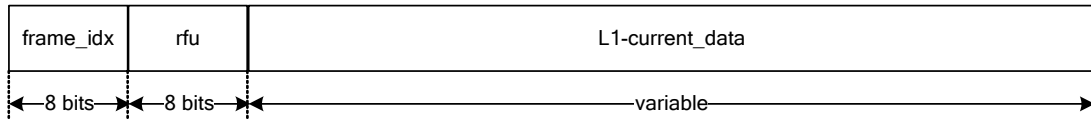

Figure 6: L1-current data payload

frame_idx (8 bits) indicates the FRAME_IDX according to [1] of the T2-frame in which the L1 signalling data is carried. This is also the T2-frame that the L1 signalling data describes.

rfu (8 bits) bits reserved for future use and shall all be set to 0₂.

L1-current_data contains fields in the order given in table 2.

NOTE: The P1 signalling is generated by the modulator from the S1 and S2 fields in the L1 pre-signalling (clause 7.2.2 of [1]).

Table 2: L1-current data fields

Field	Field length (bits)	Format	Description
L1PRE	168	bflbf	L1 pre-signalling bits in the order defined in clause 7.2.2 of [1], excluding the CRC
L1CONF_LEN	16	uimsbf	Length of L1 configurable signalling in bits
L1CONF	$8 \times \lceil L1_CONF_LEN/8 \rceil$	bflbfzpb	L1 configurable post-signalling fields, in the order defined in clause 7.2.3.1 of [1]
L1DYN_CURR_LEN	16	uimsbf	Length of L1-dynamic, current frame
L1DYN_CURR	$8 \times \lceil L1DYN_CURR_LEN/8 \rceil$	bflbfzpb	L1-post "dynamic, current frame" fields in the order defined in clause 7.2.3.2 of [1]
L1EXT_LEN	16	uimsbf	Length of L1 extension field, in bits
L1EXT	$8 \times \lceil L1_EXT_LEN/8 \rceil$	bflbfzpb	L1-post extension field as defined in clause 7.2.3.4 of [1]

The L1PRE, L1CONF and L1DYN_CURR fields are mandatory in all L1-current T2-MI packets and shall be coded in accordance with clauses 7.2.1, 7.2.3.1 and 7.2.3.2 respectively of [1].

NOTE: The L1DYN_CURR field will not be transmitted in P2 in TFS mode, but is mandatory because the information will be used by the modulator for Interleaving and Frame-Building.

5.2.4 L1-future

T2-MI packets with a **packet_type** of 11_{16} shall contain L1 post-signalling data to be inserted (according to clause 7.2.3 of [1]) into the P2 symbols of the T2-frame indicated by **frame_idx**, and/or in-band signalling data to be inserted into the first BB-Frame of the Interleaving Frame beginning in that T2-frame. The signalling contained comprises those fields that describe future T2-frames, and might therefore not be available at the time the L1-current T2-MI packet is sent. The T2-MI packet payload is shown in figure 7.

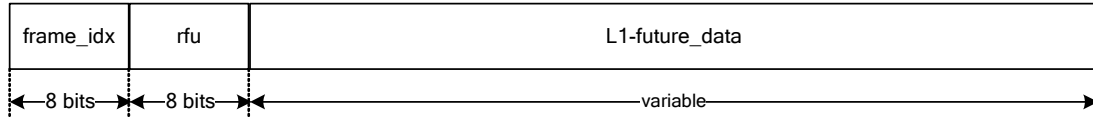

Figure 7: L1-future data payload

frame_idx (8 bits) indicates the `FRAME_IDX` according to [1] of the T2 frame in whose P2 symbols the L1 dynamic post-signalling data is carried. It also indicates the first T2-frame carrying the Interleaving Frame whose first BB-Frame will contain the in-band signalling.

Which T2-frame is described by the dynamic post-signalling and in-band signalling will depend on the use of TFS as described in clauses 7 and 5.2.3 respectively of [1]. Which T2-frame or frames are described by the in-band signalling will also depend on the interleaving parameters (P_1 and I_{jump}) for the PLP in which they are inserted, as described in clause 5.2.3 of [1].

rfu (8 bits) bits reserved for future use and shall all be set to 0_2 .

L1-future_data contains fields in the order given in table 3.

Table 3: L1-future data fields

Field	Field length (bits)	Format	Description
L1DYN_NEXT_LEN	16	uimsbf	Length of "dynamic, next frame" field. Set to zero if L1DYN_NEXT block is absent.
L1DYN_NEXT	$8 \times \lceil L1DYN_NEXT_LEN/8 \rceil$	bflbfzpb	L1-post "dynamic, next frame" fields. Optional in single-RF mode, mandatory in TFS
L1DYN_NEXT2_LEN	16	uimsbf	Length of "dynamic, next-but-one frame" in TFS mode. Set to zero if L1DYN_NEXT2 block is absent
L1DYN_NEXT2	$8 \times \lceil L1DYN_NEXT2_LEN/8 \rceil$	bflbfzpb	L1-post "dynamic, next-but-one frame" fields, in the order defined in clause 7.2.3.2 of [1]. Optional in TFS, and shall not be present in single-RF mode.
NUM_INBAND	8	uimsbf	Number of PLPs for which in-band signalling is present in the following loop.
For $i=1..NUM_INBAND \{$			In-band signalling loop
PLP_ID	8	uimsbf	PLP ID for the PLP containing the in-band signalling data given by the following INBAND field.
INBAND_LEN	16		Length of following INBAND field in bits
INBAND	$8 \times \lceil INBAND_LEN/8 \rceil$	bflbfzpb	In-band signalling fields for the PLP indicated by PLP_ID, in the order defined in clause 5.2.3 of [1]
$\}$			

Only PLPs for which the T2-frame indicated by **frame_idx** is the first T2-frame to which an Interleaving Frame is mapped shall appear in the in-band signalling loop.

The L1DYN_NEXT and L1DYN_NEXT2 fields shall be coded in accordance with clause 7.2.3.2 of [1]. The INBAND fields shall be coded in accordance with clause 5.2.3 of [1].

5.2.5 DVB-T2 timestamp

T2-MI packets with a **packet_type** of 20_{16} shall carry the DVB-T2 timestamp, used to synchronize the output of DVB-T2 modulators. Two mechanisms are defined; absolute and relative.

The T2-MI packet payload for this data is shown in figure 8.

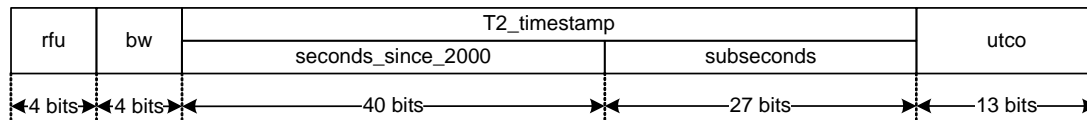

Figure 8: DVB-T2 timestamp payload

rfu (4 bits) bits reserved for future use and shall all be set to 0_2 .

bw (4 bits) indicates the system bandwidth, in accordance with clause 9.5 of [1]. This also defines the units of the subsecond field of the T2 timestamp as shown in table 4.

Table 4: Bandwidths and subsecond field units for the T2 timestamp

Bandwidth	bw field	T2 Elementary period, T	subseconds unit, T_{sub}
1.7 MHz	0_{16}	$71/131 \mu s$	$1/131 \mu s$
5 MHz	1_{16}	$7/40 \mu s$	$1/40 \mu s$
6 MHz	2_{16}	$7/48 \mu s$	$1/48 \mu s$
7 MHz	3_{16}	$7/56 \mu s$	$1/56 \mu s$
8 MHz	4_{16}	$7/64 \mu s$	$1/64 \mu s$
10 MHz	5_{16}	$7/80 \mu s$	$1/80 \mu s$

seconds_since_2000 (40 bits) is a count of the number of seconds since 2000-01-01 T 00:00:00 UTC as an unsigned 40-bit quantity and is used to define an absolute time of emission. This count shall increase for every SI second that elapses. A value of 0000000000_{16} indicates a relative timestamp, defined only by the subseconds field below.

subseconds (27 bits) defines the number of subsecond units since the time expressed in the seconds field. The value is expressed as an unsigned integer.

T2_timestamp: Taken together, the **seconds_since_2000** and **subseconds** fields define the DVB-T2 timestamp and the time of emission of a DVB-T2 transmission. Annex F details the relationship between the DVB-T2 timestamp and other time standards.

When the **seconds_since_2000** field is non-zero, the emission time shall be given by $seconds_since_2000 + subseconds \times T_{sub}$.

When the **seconds_since_2000** field is all zeros, the emission time shall be $subseconds \times T_{sub}$ after the SI second boundary preceding it.

NOTE: The SI second boundary can be given by the relevant edge of a 1 pulse per second signal.

The emission time shall be the time at which 50 % of the energy of the first time sample from the IFFT of the “C” part of the P1 preamble symbol of the first T2 transmission frame of the relevant superframe shall have been radiated on air. All T2 frames within a superframe shall have the same timestamp value. The timestamps of subsequent superframes shall be increased by the duration of the superframe.

NOTE: Based on the knowledge of the DVB-T2 Timestamp of a particular superframe, and the L1 signalling pertaining to a particular T2 frame, a modulator should be able to determine the required emission time for any such T2 frame even if it misses the beginning of a superframe, e.g. after a restart. To do this, the modulator will then need to take into account the frame index and the frame length of the T2 frame as well as the total lengths of any FEF parts having occurred in the superframe before the current T2 frame.

utco (13 bits) is the offset (in seconds) between UTC and the **seconds_since_2000** field. The value is expressed as an unsigned integer. As of February 2009, the value shall be 2 and shall change as a result of each new leap second proscribed by the International Earth Rotation and Reference Systems Service (IERS).

NOTE: The value contained in this field has no effect on the time of emission from the modulator but it may be useful to a modulator implementation where only a source of UTC time is available.

5.2.5.1 Null timestamp

When it is not required to synchronize the output of multiple DVB-T2 modulators, the DVB-T2 timestamp shall be signalled as null by setting all bits of the **T2_timestamp** and **utco** fields to 1₂.

A DVB-T2 timestamp packet must always be sent (whether carrying a Null timestamp or otherwise) to indicate the bandwidth of the T2 transmission to the T2 modulator.

5.2.6 Individual addressing

T2-MI packets with a **packet_type** of 21₁₆ shall carry individual addressing data. The T2-MI packet payload is shown in figure 9 and the individual addressing data is in the same format as clause 6.1 of [3].

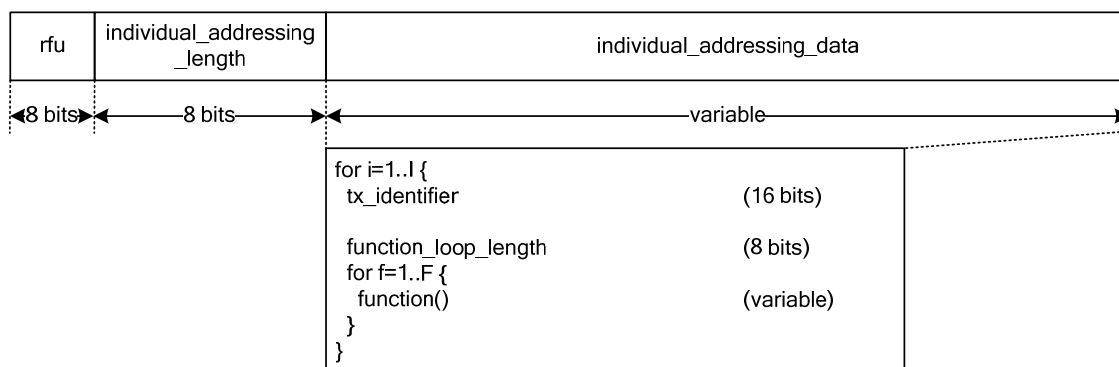

Figure 9: Individual addressing payload

individual_addressing_length (8 bits) indicates the length of the **individual_addressing_data** field in bytes.

individual_addressing_data (variable bits) is composed as follows:

tx_identifier (16 bits) is a word used to address individual transmitters. A value of '0000'₁₆ is used as a broadcast address to address all transmitters in the network.

function_loop_length (8 bits) indicates the length of the following loop of functions in bytes.

function() is the addressing function and is dependent on the application. They are defined in clause 5.2.6.1 and 5.2.6.2.

5.2.6.1 Existing addressing functions

The format of the individual addressing functions is in accordance with clause 6.1 of TS 101 191 [3]. Table 5 indicates which of the currently defined functions are also applicable to DVB-T2.

Table 5: Existing individual addressing functions

function	function_tag value	Applicable to DVB-T2?
Transmitter time offset	00 ₁₆	yes
Transmitter frequency offset	01 ₁₆	yes
Transmitter power	02 ₁₆	yes
Private data	03 ₁₆	yes
Cell id	04 ₁₆	yes
Enable	05 ₁₆	yes
Bandwidth	06 ₁₆	no

5.2.6.2 Addressing functions specific to DVB-T2

Some new functions are defined to fully support DVB-T2 as depicted in table 6. Whilst these have the same basic structure as those defined in clause 6.1 of TS 101 191 [3], the data they carry is specific to their function in a T2 system.

Table 6: Individual addressing functions specific to DVB-T2

Function	function_tag value
Transmitter PAPR	10 ₁₆
Transmitter MISO group	11 ₁₆

Each **function()** is constructed from three fields as follows:

function_tag (8 bits) is the value identifying the particular function in use as defined in tables 5 and 6.

function_length (8 bits) defines the total length of the **function()** in bytes, including the **function_tag**, **function_length** and **function_body()** fields.

function_body() is specific to the particular individual addressing function as defined in the clauses below.

NOTE: For each of the existing individual addressing functions defined in TS 101 191 [3], **function_body()** comprises all the fields that follow the **function_length** field.

5.2.6.2.1 PAPR function

The Transmitter PAPR function is used to signal the Active Constellation Extension (ACE) parameters to the DVB-T2 modulator (see clause 9.6.1 of [1]). ACE has 3 parameters, G , L and V_{clip} that must be conveyed to all the modulators that are part of an SFN to ensure that they produce identical on-air signals. Table 7 shows how these parameters are conveyed in the PAPR addressing function.

Table 7: PAPR function

Syntax	Number of bits	Format
tx_PAPR_function() {		
function_tag	8	uimsbf
function_length	8	uimsbf
function_body() {		
ACE_gain	5	uimsbf
ACE_maximal_extension	3	uimsbf
ACE_clipping_threshold	7	uimsbf
reserved_future_use	1	bflbf
}		
}		

ACE_gain (5 bits) shall be a value between 0 and 31 that represents the ACE gain, G .

ACE_maximal_extension (3 bits) shall be a value that represents the ACE maximal extension value, L as follows:
 $ACE_maximal_extension = (L - 0,7) / 0,1$

ACE_clipping_threshold (7 bits) shall be a value that represents the ACE clipping threshold, V_{clip} as follows:
 $ACE_clipping_threshold = 20 \log_{10}(V_{clip} / V_{rms}) / 0,1$

reserved_for_future_use (1 bit) is reserved for future use and shall be set to 0₂ until defined.

5.2.6.2.2 MISO group function

This function allows the MISO group (see clause 9.6.1 of [1] and Annex D) to be signalled to a DVB-T2 modulator. Table 8 shows the format of the individual addressing function

Table 8: MISO group function

Syntax	Number of bits	Format
tx_PAPR_function() {		
function_tag	8	uimsbf
function_length	8	uimsbf
function_body() {		
MISO_group	1	bflbf
reserved_future_use	7	bflbf
}		
}		

MISO_group (1 bit) indicates the MISO group. Value 0₂ indicates MISO group 1. Value 1₂ indicates MISO group 2.

reserved_for_future_use (7 bits) is reserved for future use and shall all be set to 0₂ until defined.

5.2.7 FEF part: Null

T2-MI packets with a **packet_type** of 30₁₆ shall carry information related to a FEF part, in accordance with [1], clause 8.4, during which no signal shall be generated by the modulator apart from the P1 preamble.

The T2-MI packet payload is shown in figure 10.

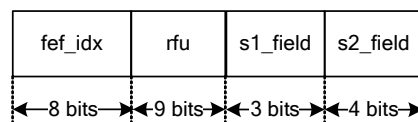

Figure 10: FEF part: Null payload

fef_idx (8 bits) indicates the index of the FEF part within the superframe. The first FEF part in a superframe shall have a fef_idx value of '0' and this shall increment by 1 for each subsequent FEF part.

rfu (9 bits) bits reserved for future use and shall all be set to 0₂.

s1_field gives the value of the S1 field in the P1 preamble of the FEF part according to clause 7.2.1 of [1].

s2_field gives the value of the S2 field in the P1 preamble of the FEF part according to clause 7.2.1 of [1].

Unless the content for the corresponding FEF part is specified by another means, the modulator shall generate a P1 preamble according to the **s1_field** and **s2_field** followed by zero modulation values for the remainder of the FEF part.

5.2.8 FEF part: I/Q data

T2-MI packets with a **packet_type** of 31_{16} shall carry information related to a FEF part, in accordance with [1], clause 8.4, together with I/Q data to be transmitted during the FEF part.

The T2-MI packet payload is shown in figure 11.

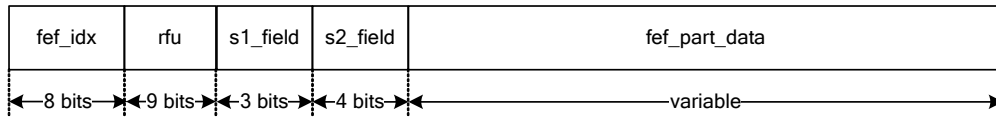

Figure 11: FEF part: I/Q data payload

fef_idx (8 bits) indicates the index of the FEF part within the superframe. The first FEF part in a superframe shall have a **fef_idx** value of '0' and this shall increment by 1 for each subsequent FEF part.

rfu (9 bits) bits reserved for future use and shall all be set to 0_2 .

s1_field gives the value of the 'S1' field in the P1 preamble of the FEF part according to clause 7.2.1 of [1].

s2_field gives the value of the 'S2' field in the P1 preamble of the FEF part according to clause 7.2.1 of [1].

fef_part_data carries the IQ data for each FEF part. It shall consist of the complex sample values in time order, starting from the first sample after the end of the P1 preamble, at a sampling rate of $1/T$ as defined in clause 9.5 of [1]. Each sample value shall be sent as a 12-bit two's complement value I for the real part immediately followed by a 12-bit two's complement value Q for the imaginary part of the complex number. The sample value, $p_{FEF}(t)$, shall be given by:

$$\begin{aligned} \text{Re}(p_{FEF}(t)) &= \frac{I}{2^9} \\ \text{Im}(p_{FEF}(t)) &= \frac{Q}{2^9} \end{aligned}$$

where I and Q are the 12-bit two's complement values represented as integers in the range -2^{11} to $2^{11}-1$. The transmitted signal $s(t)$ during the T2 frames is defined in clause 9.5 of [1], and the signal during the FEF parts, using the same scaling, shall be given by:

$$s(t) = \text{Re}\left\{e^{j2\pi f_c t} p_{FEF}(t)\right\}$$

NOTE: This allows a peak modulation magnitude, with any phase, of 12dB above the rms level of the signal during the T2-frames. The quantisation noise is approximately 59dB below the rms level of the T2-frames.

When this T2-MI packet type is used, the mean power of the complex samples $E(|p_{FEF}|^2)$ shall not exceed unity.

If more than one T2-MI packet is used for a particular FEF part, the payload of T2-MI packets with an unfinished stream shall end with a completed sample. The next sample value for that FEF part shall then start at the beginning of the payload of the next T2-MI packet with **packet_type** 31_{16} with the same **fef_idx**. All T2-MI packets of type 31_{16} with a given **fef_idx** shall have the same value of **s1_field** and **s2_field**. The total number of complex samples shall equal $FEF_LENGTH-2048$ where FEF_LENGTH is the L1-post configurable signalling field defined in clause 7.2.3.1 of [1].

5.3 Generation of L1 signalling from the T2-MI packets

The behaviour of a DVB-T2 modulator operating with a T2-MI signal as described by the present document is defined by the DVB-T2 specification [1] of the signal-on-air combined with the definition of the content of the various T2-MI packets, together with certain configuration parameters for the individual modulator.

Modulators will generate the L1-pre signalling by assembling:

- The L1PRE field from L1-current (type 10₁₆) T2-MI packet having **frame_idx** equal to FRAME_IDX of the T2-frame being generated, and
- the CRC generated by the modulator itself

Modulators will generate the L1-post signalling for a given T2-frame by assembling:

- the L1CONF from the relevant L1-current (type 10₁₆) T2-MI packet,
- the appropriate combination of L1_DYN_CURR from the relevant L1-current (type 10₁₆) T2-MI packet, and L1_DYN_NEXT and L1_DYN_NEXT2 from the relevant L1-future (type 11₁₆) T2-MI packet, as given in table 9,
- the L1_EXT from the relevant L1-current (type 10₁₆) T2-MI packet, if present, and
- the CRC generated by the modulator itself,

where the relevant packet is the one having **frame_idx** equal to FRAME_IDX of the T2-frame being generated.

Table 9: The combination of L1-dynamic fields used to generate the L1-post signalling

	L1_REPETITION_FLAG=0	L1_REPETITION_FLAG=1
NUM_RF=1 (non-TFS)	L1_DYN_CURR	L1_DYN_CURR, L1_DYN_NEXT
NUM_RF>1 (TFS)	L1_DYN_NEXT	L1_DYN_NEXT, L1_DYN_NEXT2

NOTE: In TFS, the L1_DYN_CURR field is never transmitted in the P2 symbols. However, the information in this field is needed by the modulator for interleaving and frame building and so is always sent in the L1-current T2-MI packet.

A modulator may replace the CELL_ID field in the L1-pre signalling and/or the FREQUENCY field(s) in the configurable L1-post signalling. Modulators operating in the same Single-Frequency Network (SFN) shall all use the same values of these fields.

NOTE: If these fields are modified within a modulator this is done prior to calculation of the CRCs.

5.4 Transmission order of T2-MI packets

The T2-MI packets with packet_type 00₁₆ (BB-Frames) for a given PLP shall be sent in the original order of the Baseband Frames they encapsulate. The transmission of such T2-MI packets is mandatory.

The T2-MI packets with packet_type 01₁₆ (Auxiliary streams) with a given value of aux_id shall be sent in the order of increasing cell address of the first cell that they carry.

T2-MI packets of type 00₁₆ for different PLPs and T2-MI packets of type 01₁₆ for different values of aux_id may be multiplexed together in any order, provided the above conditions are met.

NOTE: The **frame_idx** in T2-MI packets of type 00₁₆ may change at different times for different PLPs. For example, type 00₁₆ packets for one PLP for frame $m+1$ may be sent before type 00₁₆ packets for a different PLP for frame m . This is particularly likely when multi-frame interleaving is in use.

Immediately following the last transmitted T2-MI packet with packet_type 00₁₆ or 01₁₆ to be used for the construction of a particular T2 frame, the following T2-MI packets shall be sent in the order set out below:

- one T2-MI packet with packet_type 20₁₆ (DVB-T2 timestamp) pertaining to the same T2 frame. The transmission of such a T2-MI packet for each T2 frame is mandatory. Where SFN synchronization is not required the DVB-T2 timestamp shall be null (see clause 5.2.5.1).
- one T2-MI packet with packet_type 10₁₆ (L1-current data) pertaining to the same T2 frame. The transmission of one such T2-MI packet per T2 frame is mandatory.

If in-band signalling, L1-repetition or TFS are used, a T2-MI packet of type 11₁₆ (L1-future) for the T2-frame shall be sent at a later time.

When the T2-MI packet with packet_type 11₁₆ (L1-future) is used it shall always be the last T2-MI packet with a given **frame_idx** and the T2-MI packet of type 10₁₆ (L1-current) shall be the second-to-last packet with a given **frame_idx**. Otherwise the T2-MI packet of type 10₁₆ (L1-current) shall be the last T2-MI packet with a given **frame_idx**.

5.5 Timing of T2-MI packet transmission

In this clause, $T_{\min1}$, $T_{\min2}$, $T_{\min3}$, $T_{\max1}$, $T_{\max2}$, $T_{\max3}$ and $T_{\max4}$ represent specification values for a modulator and should be quoted by modulator manufacturers. Network operators should design the timing of a network carrying T2-MI taking into account the values for each of the modulators in the network.

The T2-MI packets of type 00₁₆, 01₁₆, 10₁₆ and 20₁₆ with a given **frame_idx** shall be sent so as to arrive at the modulator no later than $T_{\min1}$ before the beginning of the corresponding T2-frame is due for transmission.

The T2-MI packet of type 11₁₆, if used, with a given **frame_idx**, shall be sent so as to arrive at the modulator no later than $T_{\min2}$ before the beginning of the corresponding T2-frame is due for transmission.

T2-MI packets of type 30₁₆, and 31₁₆ with a given **fef_idx** shall arrive no later than $T_{\min3}$ before the corresponding FEF part is due for transmission.

T2-MI packets of type 00₁₆ with a given **frame_idx** shall arrive no earlier than $T_{IF}+T_{\max1}$ before the beginning of the corresponding T2-frame is due for transmission, where $T_{IF}=P_I \times J_{\text{jump}} \times T_F$ is the duration of one Interleaving Frame for the corresponding PLP.

T2-MI packets of type 01₁₆ with a given **frame_idx** shall arrive no earlier than $T_{\max2}$ before the beginning of the corresponding T2-frame is due for transmission..

T2-MI packets of type 10₁₆, 11₁₆, and 20₁₆ with a given **frame_idx** shall arrive no earlier than $T_{\max3}$ before the beginning of the corresponding T2-frame is due for transmission.

T2-MI packets of type 30₁₆, and 31₁₆ with a given **fef_idx** shall arrive no earlier than $T_{\max4}$ before the corresponding FEF part is due for transmission.

For the purposes of this clause, the time of arrival of a T2-MI packet at the modulator shall be defined as the time at which the packet is delivered by the underlying DVB data piping protocol (see clause 6.1).

6 Transport of T2-MI packets

The structure of the T2-MI protocol stack described in clause 4.3 allows two mechanisms for distribution; one for traditional ASI interfaces, the other for IP based networks.

Both mechanisms rely on first inserting the T2-MI packets into DVB/MPEG-2 TS packets which can then be interfaced to a distribution network via such interfaces as described in EN 50083-9 [i.2].

The resulting TS can then be further encapsulated into an IP stream using the DVB IPTV standard, TS 102 034 [5]

6.1 Encapsulation of T2-MI packets in MPEG-2 TS

The insertion of T2-MI packets into MPEG-2 TS packets shall be in accordance with ETSI EN 301 192 [4], clause 4, “Data Piping”. This mechanism allows for the insertion of data directly into the payload of MPEG-2 TS packets with the minimum of additional overhead.

6.1.1 Description

The T2-MI packets are inserted, one after another, into the payload of MPEG-2 TS packets. Each new T2-MI packet shall start immediately following the previous one. A TS packet may contain more than one T2-MI packet. T2-MI packets that are too big to fit into the payload of a single TS packet shall be split across multiple TS packets as required.

Since the length of each T2-MI packet is variable (indicated by the **payload_len** field in the T2-MI packet header), the start of a TS packet's payload does not necessarily coincide with the start of a T2-MI packet. To enable synchronisation within a device receiving T2-MI, the 'payload_unit_start_indicator' bit in the TS header shall be used to indicate that a new T2-MI packet starts somewhere within the current TS packet. When this is the case an 8-bit pointer shall be positioned as the first payload byte of the TS packet, indicating the offset from the start of the TS payload to the first byte of the first T2-MI packet. This 8-bit pointer field (uimsbf) shall indicate the number of bytes immediately following the pointer field until the first byte of the first T2-MI packet that is present in the payload of the Transport Stream packet (i.e. a value of 00_{16} in the pointer field indicates that the T2-MI packet starts immediately after the pointer field). This is illustrated in figure 12.

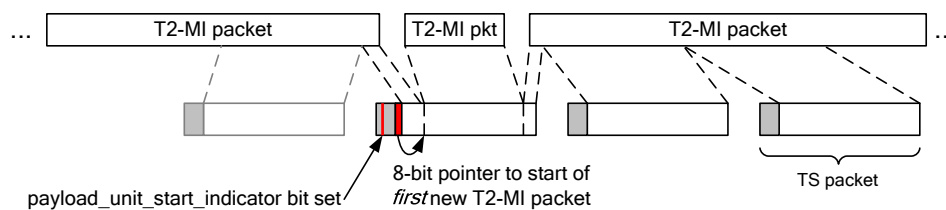

Figure 12: Encapsulation of T2-MI Packets in MPEG-2 TS

Using this mechanism the T2-MI packet can begin anywhere in the TS packet. There is no requirement to have T2-MI packets beginning at the start of a TS packet and no need for unnecessary stuffing.

NOTE: Since the TS packets containing T2-MI packets are carrying a data type not defined by MPEG, EN 301 192 [4] allows the use of the 'payload_unit_start_indicator' bit in this “service private way”.

When a T2-MI packet ends at the last-but-one byte of a TS packet and starts in a previous TS packet, the one remaining byte does not allow space for both the insertion of the 8-bit pointer field and the first byte of the next T2-MI packet. In this case the size of the payload of the TS packet shall be reduced by one byte through the use of adaptation field stuffing [7] such that the current T2-MI packet finishes at the end of the TS packet payload. The next T2-MI packet shall start in the next TS packet having the same PID.

NOTE: Arbitrary amounts of padding may also be added, if required, at this layer through the use of arbitrary numbers of stuffing bytes in the adaptation field of the transport stream packet [7].

EXAMPLE: A T2-MI packet is being transmitted. Most of the T2-MI packet has been transmitted and only 50 bytes remain to be sent. The next T2-MI packet is not yet available and there are therefore not enough bytes to fill up a TS packet. To allow this TS packet to be transmitted immediately, an adaptation field of total length 134 bytes ($\text{adaptation_field_length} = 133$) containing stuffing bytes can be inserted before the payload.

For carriage over managed distribution networks it may be necessary to add a minimum of PSI in order to prevent erroneous alarms from being set. This would normally comprise a PAT, and PMT for a single “Program” as defined in ISO/IEC 13818-1 [7]. The Stream Type to be used in the PMT is not defined in EN 301 192 [4]. For the purposes of interoperability, it should be set to 06_{16} .

Similarly, some networks may require the carriage of mandatory DVB SI tables, and reference should be made to EN 300 468 [8] for the appropriate values to be used in such tables.

When $\text{NUM_RF}=1$, the maximum rate of the transport stream carrying the T2-MI shall be 72 Mbps.

6.2 Encapsulation of MPEG-2 TS in IP packets

A DVB-T2 modulator may support the transport of MPEG-2 TS over IP. In case the DVB-T2 modulator supports IP-based delivery, the transport of MPEG-2 TS over IP shall follow the specification in this clause. The transport of MPEG-2 TS over IP relies on the methods specified in ETSI TS 102 034 [5]. This clause specifies a protocol for FEC

protected multicast delivery of MPEG-2 Transport Streams over RTP and is based on IP version 4 according to [5]. IP version 6 is not supported.

Unicast delivery of MPEG-2 Transport Streams over IP is outside the scope of the specification. However, the unicast transport may rely on the same protocol as specified in clause 6.2.2. below.

6.2.1 Setup Information

For delivering FEC-protected, multicast MPEG-2 Transport Streams over RTP using the protocols in ETSI TS 102 034 [5], the following setup information should be provided according to [5], clause 5.2.6.2, Table 4:

- IPMulticastAddress:
 - IPMulticastAddress@Source: Optionally the IP unicast address of the source of the TS may be provided.
 - IPMulticastAddress@Address: Provides the multicast address at which the service may be accessed.
 - IPMulticastAddress@Port: Provides the port at which the service may be accessed.
 - FECBaseLayer: Contains the multicast address and port of the AL-FEC stream. This element shall be present if the FECBaseLayer element is present.
 - FECBaseLayer@Address: IP Multicast Address for FEC Base Layer. If the IP multicast address is omitted, then the FEC flow is assumed to be on the same multicast address as the original data.
 - FECBaseLayer@Source: IP Multicast Source Address for FEC Base Layer. If the IP multicast source address is omitted, then the FEC flow is assumed to be on the same multicast source address as the original data.
 - FECBaseLayer@Port: UDP port for FEC Base Layer.
 - FECEnhancementLayer: Contains the multicast address and port of the AL-FEC enhancement stream(s). This element shall only be present if the FECBaseLayer element is present. This element may be repeated for multiple layers.
 - FECEnhancementLayer@Address: IP Multicast Address for FEC Enhancement Layer. If the IP multicast address is omitted, then the FEC flow is assumed to be on the same multicast address as the original data
 - FECEnhancementLayer@Source: IP Multicast Source Address for FEC Enhancement Layer. If the IP multicast source address is omitted, then the FEC flow is assumed to be on the same multicast source address as the original data
 - FECEnhancementLayer@Port: UDP port for FEC Enhancement Layer.
 - IPMulticastAddress@FECMaxBlockSizePackets: This indicates the maximum number of stream source packets that will occur between the first packet of a source block (which is included) and the last packet for that source block (source or repair).
 - IPMulticastAddress@FECMaxBlockSizeTime: The maximum transmission duration of any FEC Block (source and repair packets)
 - IPMulticastAddress@FECObjectTransmissionInformation: The FEC Object Transmission Information for the Raptor code. If an FECEnhancementLayer element is included then this element shall be included.

For details of the semantics of these parameters refer to [5].

6.2.2 Transport Protocols

Where the MPEG-2 TS is transported over IP, the MPEG-2 TS shall be encapsulated in RTP (Real-time Transport Protocol) according to RFC 3550 [6] as specified in ETSI TS 102 034 [5], clause 7.1.1.

RTCP sender reports and receiver reports shall not be used.

FEC protection of the MPEG-2 Transport Stream may be provided according to ETSI TS 102 034 [5], clauses E.3 and E.4. When a DVB AL-FEC enhancement layer is provided, the FEC Scheme defined in ETSI TS 102 034 [5], E.4.3.2 shall be used.

DVB-T2 modulators that support the transport of MPEG-2 TS over IP shall support the minimum decoder requirements according to [5], E.5.1.1, i.e. FEC decoders shall support processing of the DVB AL-FEC base layer packets.

DVB-T2 modulators that support the transport of MPEG-2 TS over IP may support the enhanced decoder requirements according to [5], E.5.1.2, i.e. FEC decoders may support processing of the DVB AL-FEC base layer and DVB AL-FEC enhancement layer packets.

6.2.3 Session Initiation and Control

Session initiation is outside the scope of the specification. The session initiation and control for the multicast distribution according to ETSI TS 102 034 [5], clause 7.3.1 may be used.

6.2.4 Network Requirements

The network requirements for the multicast distribution shall be in accordance with ETSI TS 102 034 [5], clause 7.2.

In case application layer FEC is applied, the network requirements may be relaxed. For configuration examples of application layer FEC for different network characteristics, refer to DVB bluebook A115 [i.3].

Annex A (normative): Calculation of the CRC word

The implementation of Cyclic Redundancy Check codes (CRC-codes) allows the detection of transmission errors at the receiver side. For this purpose CRC words shall be included in the transmitted data. These CRC words shall be defined by the result of the procedure described in this annex.

A CRC code is defined by a polynomial of degree n :

$$G_n(x) = x^n + g_{n-1}x^{n-1} + \dots + g_2x^2 + g_1x + 1$$

with $n \geq 1$:

and: $g_i \in \{0,1\}$, $i = 1, \dots, n-1$

The CRC calculation may be performed by means of a shift register containing n register stages, equivalent to the degree of the polynomial (see figure A.1). The stages are denoted by $b_0 \dots b_{n-1}$, where b_0 corresponds to 1, b_1 to x , b_2 to x^2, \dots, b_{n-1} to x^{n-1} . The shift register is tapped by inserting XORs at the input of those stages, where the corresponding coefficients g_i of the polynomial are "1".

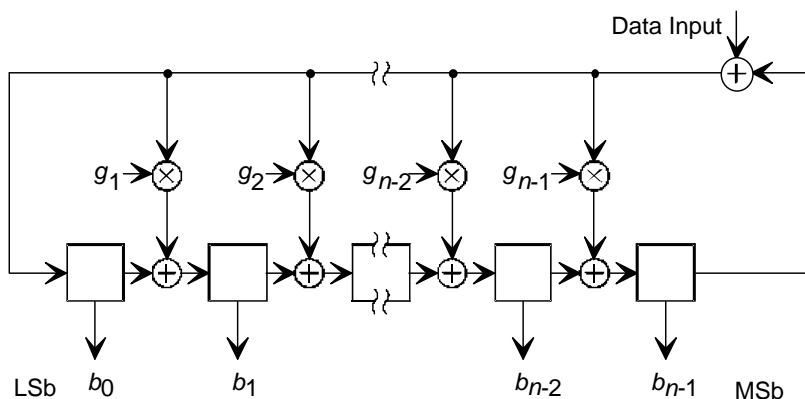

Figure A.1: General CRC block diagram

At the beginning of the CRC-32 calculation all register stage contents are initialized to ones.

After applying the first bit of the data block (MSB first) to the input, the shift clock causes the register to shift its content by one stage towards the MSB stage (b_{n-1}), while loading the tapped stages with the result of the appropriate XOR operations. The procedure is then repeated for each data bit. Following the shift after applying the last bit (LSB) of the data block to the input, the shift register contains the CRC word which is then read out. Data and CRC word are transmitted with MSB first.

The CRC code used in the T2-MI packet is based on the following polynomial:

- $G_{32}(x) = x^{32} + x^{26} + x^{23} + x^{22} + x^{16} + x^{12} + x^{11} + x^{10} + x^8 + x^7 + x^5 + x^4 + x^2 + x + 1$

NOTE: The CRC-32 coder defined in this annex is identical to that specified in Annex F of the DVB-T2 system specification [1].

Annex B (normative): T2 Modulator Information Packet (T2-MIP)

B.1 Use of the T2-MIP for over the air synchronization

The T2-MI packets, as described in the main body of the present document, are only used by the modulator and not broadcast from the transmitter. For use cases where several repeaters are receiving a DVB-T2 signal from a main transmitter and retransmitting it on a common second frequency, in an SFN, there is a need to make this retransmission from the repeaters in a time-synchronized way. This situation is detailed in Figure B.1.

There are two types of repeater. They may be

- regenerative repeaters, i.e. demodulating the DVB-T2 signal and the re-modulating the demodulated transport streams to form a regenerated DVB-T2 signal which is then retransmitted or
- transposers, i.e. they would shift frequency, amplify, delay and transmit the received DVB-T2 signal without a full re-modulation process taking place.

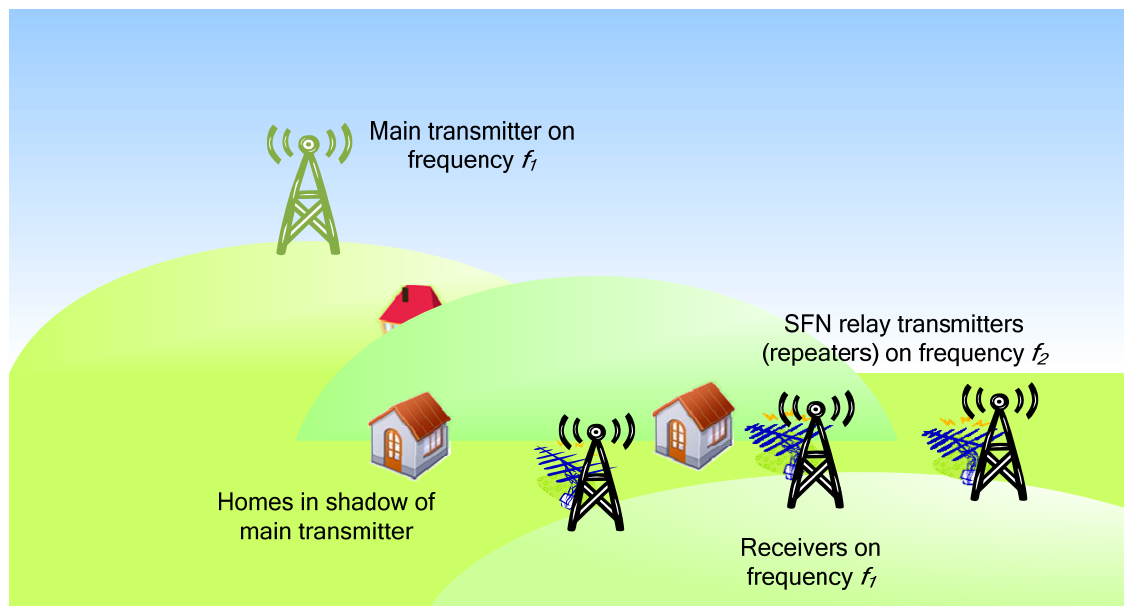

Figure B.1: SFN Relays taking input over the air from the Main transmitter

In this situation, the relay transmitters do not have access to the T2-MI packets that were used by the modulator at the main transmitter to generate the on-air, physical layer, T2 signal.

Because the physical layer signal has been defined at the main transmitter, the only synchronization data required by the relay is the time of emission. This is carried by a special Transport Stream packet (the T2-MIP) which is carried in the over-air DVB-T2 signal.

This TS packet can be decoded by a demodulator in each repeater to extract the required emission time of a particular superframe of the DVB-T2 signal. Based on this information, and on the knowledge of the timing of the currently-received superframe, each repeater can apply the appropriate time delay to ensure emission of the superframe at the required time.

This version of the T2-MI specification only defines the T2-MIP to be carried over transport streams, which is derived from the equivalent packet used in DVB-T networks [3]. There is currently no equivalent specification for such a mechanism to synchronize networks carrying services over other transports, such as GSE.

See Figure B.2 for the architecture of such a network.

NOTE: The T2-MIP inserter resides in the T2 Gateway, as it is this unit that defines the construction of the T2 Frame and Superframe, and hence the timing relationship of TS packets to the physical layer modulation.

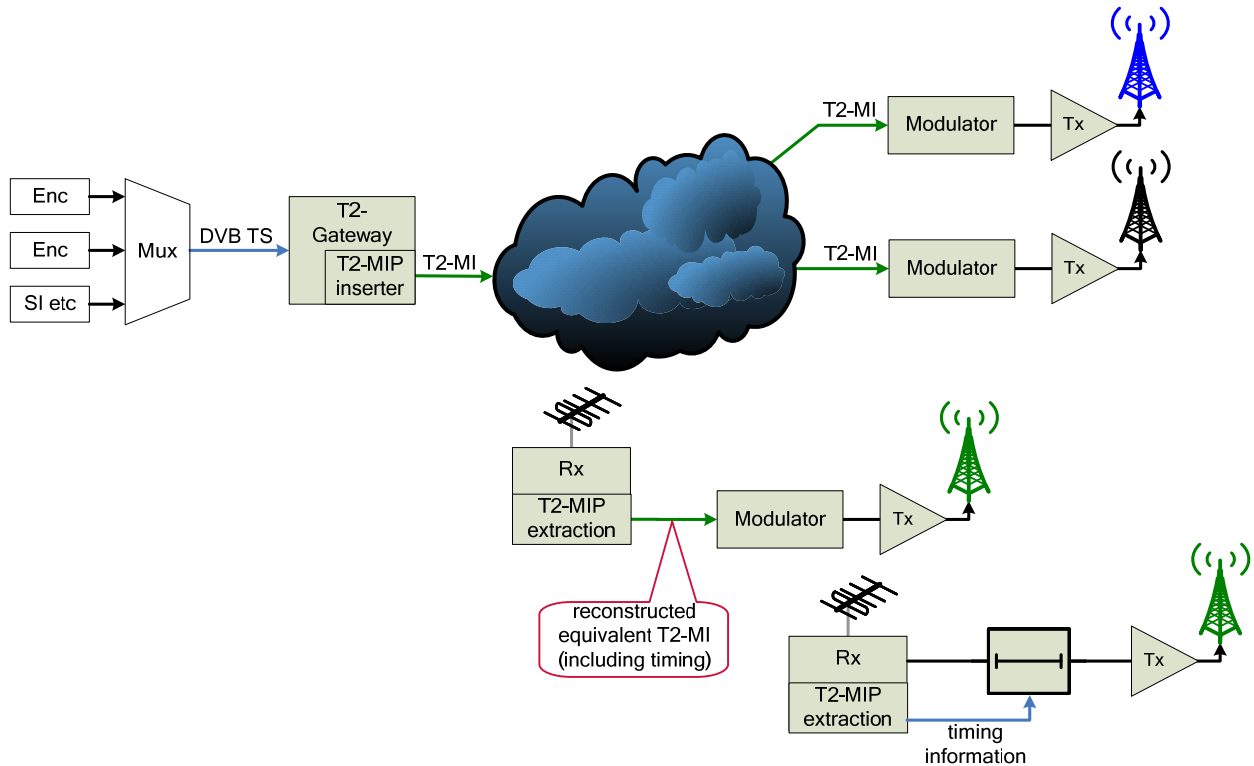

Figure B.2: Generic architecture of over-air distribution of the T2-MIP to a SFN Sub-network

Under this condition, it is envisaged that the receiver at the relay station would deconstruct the incoming DVB-T2 signal into the constituent parts such that it could effectively pass an equivalent of the T2-MI signal on to the relay's modulator. This is necessary to ensure that every relay's modulator constructs the air interface identically at each station in the SFN.

B.2 T2-MIP Definition

B.2.1 Field description

The T2-MIP is an MPEG-2 compliant Transport Stream (TS) packet [7], made up of a 4 byte header and 184 data bytes. The organization of the MIP is shown in B.1.

Table B.1: DVB-T2 Modulator Information Packet (T2-MIP)

Syntax	Number of bits	Identifier
t2_modulator_information_packet() {		
transport_packet_header	32	bslbf
synchronization_id	8	uimsbf
section_length	8	uimsbf
t2_timestamp_mip_length	8	uimsbf
t2_timestamp_mip	88	bslbf
rfu_length	8	uimsbf
for i = 1..rfu_length { rfu_byte	8	uimsbf
}		
individual_addressing_length	8	uimsbf
for j = 1..individual_addressing_length { individual_addressing_byte	8	uimsbf
}		
crc_32	32	rpchof
for k = 1..stuffing_length { stuffing_byte	8	uimsbf
}		
}		
NOTE 1: Optional parameters are shown in <i>italic</i> .		
NOTE 2: The total length of a T2-MIP shall always be 188 bytes.		

transport_packet_header (32 bits) shall comply with ISO/IEC 13818-1 [7] subclause 2.4.3.2, table 3 and table 4.

- The PID value for the T2-Modulator Information Packet (T2-MIP) shall be 15_{16} .
- The `payload_unit_start_indicator` is not used by the SFN synchronization function and shall be set to 1.
- The `transport_priority` value is not used by the SFN synchronization function and shall be set to 1.
- The `transport_scrambling_control` value shall be set to 00 (not scrambled).
- The `adaptation_field_control` value shall be set to 01 (payload only).
- All other parameters are according to ISO/IEC 13818-1 [7] subclause 2.4.3.2.
- The Transport Packet Header (TPH) is mandatory.

Mandatory T2-MIP fields

synchronization_id (8 bits) is used to identify the synchronization scheme used. For DVB-T2 the value shall be 02_{16} .

NOTE: The values of **synchronization_id** that apply for different transmissions systems are defined in Table 2 of TS 101 191 [3].

section_length (8 bits) specifies the number of bytes following immediately after the `section_length` field until, and including, the last byte of the **crc_32** but not including any `stuffing_byte`. The `section_length` shall not exceed 182 bytes.

t2_timestamp_mip_length (8 bits) specifies the length in bytes of the **t2_timestamp_mip** field that follows. The value is currently fixed at 11_{10} .

t2_timestamp_mip (88 bits) is in the identical format to that specified for the complete payload of the T2-MI packet with packet type 20_{16} (see clause 5.2.5). The values expressed by this field refer to the emission time from the repeater of the T2 superframe in which the last bit of the payload of the TS packet carrying the T2-MIP appears.

NOTE: The value of the T2 timestamp carried by the T2-MIP may be different from that contained in packet type 20_{16} of the T2-MI interface being used as input to the modulator of the main station.

rfu_length (8 bits) specifies the number of **rfu_bytes** that follow. A value of 00_{16} indicates that there are no following **rfu_bytes**. This value is currently fixed at 00_{10} , i.e. there are no **rfu_bytes** defined.

rfu_byte is one byte of a variable number of bytes that are reserved for future use, the number of which is defined by the **rfu_length** field. All bytes shall have the value 00_{16} .

individual_addressing_length (8 bits) gives the total length of the individual addressing loop in bytes. If individual addressing of transmitters is not performed the field value is 00_{16} and there shall be no **individual_addressing_byte** field.

individual_addressing_byte contains the bytes of the **individual_addressing_data** field of a T2-MI packet of type 21_{16} (see clause 5.2.6).

crc_32 (32 bits) is calculated across all other bits in the packet, including the **transport_packet_header** but excluding the **stuffing_byte** field, in accordance with Annex A.

stuffing_byte shall have the value FF_{16} . There shall be a multiple of **stuffing_bytes** such that the **t2_modulator_information_packet** is exactly 188 bytes long.

NOTE: Whilst the values for the **t2_timestamp** field and the **individual_addressing_bytes** shall follow the format of the payloads of T2-MI packet types 20_{16} and 21_{16} respectively, the values carried may be different to those carried in these packets within the T2-MI.

B.2.2 Transmission of the T2-MIP over DVB-T2

The T2-MIP may be transmitted in one or more of the transport streams being sent over DVB-T2. If the T2-MIP is used there has to be at least one complete T2-MIP within a T2 superframe. The T2-MIP may be sent at any time within the superframe and the timing may be different from superframe to superframe (see the definition of the **t2_timestamp_mip** field in clause B.2.1).

Where multiple PLPs are used, only one of the PLPs should carry a T2-MIP. If it is carried in multiple PLPs then the T2 timestamp shall be identical within all PLPs for that superframe.

NOTE: Where a common PLP is available, this is the preferred location for the T2-MIP.

Annex C (informative): Local Content Insertion

When carrying the data for a T2 transmission containing multiple PLPs, local content can be inserted into individual PLPs into the T2-MI at a point or points downstream of the T2-gateway. This annex describes one way of achieving this.

A typical application is shown in Figure C.1.

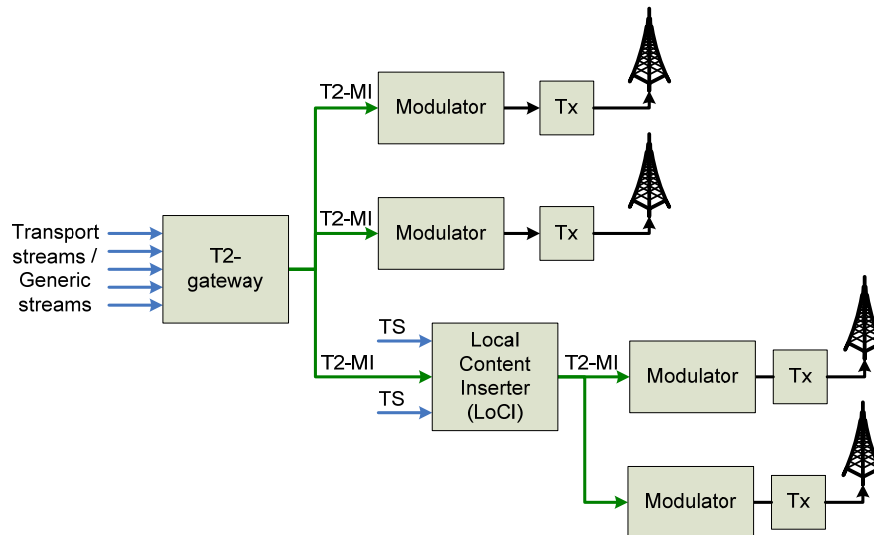

Figure C.1: Local content insertion into a T2-MI stream within a T2-system

A Local Content Inserter (LoCI) takes as its input the T2-MI stream generated in the T2-gateway, inserts any local content and outputs the resulting T2-MI stream.

For PLPs that are to carry locally inserted content, the T2-gateway performs the allocation of all BB frames as normal; generating type 00_{16} T2-MI packets that are both consistent with the L1 signalling carried in type 10_{16} and 11_{16} T2-MI packets and that have the correct timing.

For a given PLP, the LoCI filters the incoming type 00_{16} T2-MI packet (carrying Baseband Frames) based on the `plp_id` field (see clause 5.2.1). The BBFRAME data field of every T2-MI packet with a matching `plp_id` field, is then replaced with the local content, using BB frame padding as appropriate. The resulting T2-MI packets must be syntactically correct including the calculation of the CRC32 field.

Where no content is available at the T2-gateway to fill those BB frames pertaining to PLPs that are to be later replaced in a LoCI, the BB frames may be of zero datafield length (DFL = 0), i.e. all padding.

The LoCI can deal with the timing between the incoming T2-MI and the local transport streams at the input to the LoCI. in a number of ways. There are three possibilities:

- The local transport stream is locked to the T2-MI and is at a rate that exactly matches that needed to fill the BB frames to be replaced.
- The local transport stream rate is lower than that needed to exactly fill the BB frames to be replaced and BB frame padding is inserted by the LoCI
- The local transport stream rate is lower than that needed to exactly fill the BB frames to be replaced and Null TS packets are inserted into the BB frames by the LoCI. In this case the LoCI must perform any necessary restamping.

This method of local content insertion has the advantage that the LoCI can be a simple device that does not require any knowledge of the SFN timestamp. The disadvantage is that bitrate must be allocated on the link carrying the original T2-MI from the T2-gateway for BB frames that are to be replaced with local content.

Annex D (informative): MISO Management

As described, the T2-MI is designed to ensure that modulators in a network all generate identical signals at identical times. When the MISO option of DVB-T2 is used, as described in clause 9.1 of [1], the modulators belonging to transmitter group 1 are required to generate different signals to those in transmitter group 2. Nevertheless, all modulators in the network carry identical Baseband Frames and L1-signalling, with identical timing, so the same T2-MI stream is therefore sufficient for all modulators. In addition, each modulator needs to be configured as belonging to either group 1 or group 2. This can be seen as another modulator-specific parameter, similar to the power, frequency or individual time offset, and may be configured locally at the modulator, by a central control system, or using the individual addressing function described in clause in the described in clause 5.2.6

Annex E (informative): T2-MI overhead

This annex gives an indication of the overhead associated with the encapsulation of T2 data within T2-MI packets and the additional overhead involved in the transport of T2-MI over MPEG-2 Transport Stream or IP both with and without the use of Forward Error Correction (FEC).

E.1 Encapsulation of T2 data within T2-MI packets

The encapsulation of T2 data within T2-MI packets (clause 5.1) requires an overhead due to:

- the T2-MI header (6 bytes),
- the crc32 field (4 bytes) and
- the additional fields within the T2-MI packet payload associated with the carriage of BB frames (3 bytes).

For a typical T2 configuration (as given in clause 4.3 of [i.1]), the payload of the BB-frames is $K_{\text{bch}} = 38\,688$ bits.

Excluding L1-signalling and assuming that there is no timestamp or auxiliary stream information, the overhead associated solely with carriage of the Baseband Frame data over T2-MI is: $13 / (38\,688 / 8) \times 100 = 0,27\%$

E.2 Transport of T2-MI packets

E.2.1 T2-MI packets over MPEG-2 TS

Encapsulation of T2-MI packets within 188-byte MPEG-2 TS packets using “data piping” (clause 6.1) requires an overhead due to:

- the TS header (4 bytes).

Assuming that the overhead due to the pointer to the start of the T2-MI packet is negligible, the resulting overhead is therefore $4 / (188 - 4) = 2,2\%$

NOTE: This value does not take into account any null packets inserted to keep the TS bit rate constant and any additional PSI/SI information to be compliant with ETSI TR 101 290. The contribution of at least one PAT table and one PMT table with a data broadcast descriptor is assumed to be negligible.

E.2.1.1 FEC overhead for an ASI link

Where FEC is required on a physical ASI link carrying the T2-MI packets over MPEG-2 TS, RS(188,204) can be used. This results in an additional 8,5% overhead.

The total overhead (T2-MI packets over ASI plus FEC) is $(16 + 4) / (188 - 4) = 10,9\%$.

E.2.2 T2-MI packets over MPEG-2 TS to IP

Encapsulation of TS streams in RTP/UDP/IP packets according to clause 6.2 results in an overhead due to:

- the RTP header (12 bytes),
- the UDP header (8 bytes) and
- the IP header (20 bytes) (without options).

Typically, a maximum of 7 MPEG-2 TS packets are encapsulated into one IP packet to remain below the Ethernet MTU and hence avoid fragmentation.

The resulting overhead is therefore: $40 / (188 \times 7) = 3\%$.

The total overhead for T2-MI packets over MPEG-2 TS to IP is $(40 + 4 \times 7) / (184 \times 7) = 5,3\%$.

When the Ethernet header is taken into account, the total overhead for T2-MI packets over MPEG-2 TS to IP is $(40 + 18 + 4 \times 7) / (184 \times 7) = 6,7\%$.

E.2.2.1 FEC overhead

The additional overhead due to the FEC schemes defined in ETSI TS 102 034 [5] can vary a great deal depending on the chosen FEC profile. As an illustration two cases are considered below.

For a 1-D SMPTE 2022-1 code with 20 columns:

The additional overhead is $(40 + 12 + 188 \times 7) / (20 \times (40 + 188 \times 7)) = 5\%$.

The total overhead for T2-MI packets over MPEG-2 TS to IP with FEC is $20 \times (40 + 4 \times 7) + (40 + 12 + 188 \times 7) / (20 \times (184 \times 7)) = 10,6\%$ (12,1% including Ethernet header)

For a 1-D SMPTE 2022-1 code with 4 columns:

The additional overhead is $(40 + 12 + 188 \times 7) / (4 \times (40 + 188 \times 7)) = 25,2\%$.

The total overhead for T2-MI packets over MPEG-2 TS to IP with FEC is $4 \times (40 + 4 \times 7) + (40 + 12 + 188 \times 7) / (4 \times (184 \times 7)) = 31,8\%$ (33,7% including Ethernet header).

E.3 Summary of the overheads associated with T2-MI

The total overhead due to the encapsulation of T2-MI packets over ASI or Ethernet physical layers is shown in table E.1.

Table E.1: Summary of the T2-MI overhead when transported over different physical layers

Physical layer	Total overhead	FEC scheme	Additional overhead due to FEC	Total overhead including FEC
ASI	2,2%	RS(188,204)	8,5%	10,9%
Ethernet	6,7%	1-D SMPTE, 20 column	5%	12,1%
		1-D SMPTE, 4 column	25,2%	33,7%

Annex F (informative): DVB-T2 Timestamps

F.1 Relationships

The relationships between UTC, TAI, GPS Time and the DVB-T2 Timestamp (as defined in clause 5.2.2) are, as at the time of writing (February 2009), as follows:

- $GPS = TAI - 19 \text{ s}$ (constant).
- $UTC = TAI - 34 \text{ s}$ (variable due to leap seconds).
- $UTC = GPS - 15 \text{ s}$ (variable due to leap seconds).
- $UTC = DVB-T2 - utco$ (constant due to varying value of $utco$).
- $DVB-T2 = TAI - 32 \text{ s}$ (constant).
- $DVB-T2 = GPS - 13 \text{ s}$ (constant).
- $DVB-T2 = UTC + utco$ (constant due to varying value of $utco$).

F.2 Rationale

Several other standard time/date encodings are in common use, including MJD, UTC, GPS and TAI. It was agreed that none of these adequately addressed the needs of a DVB-T2 system and that it was desirable to define a time format specifically for the DVB-T2 Timestamp. The following reasons were given for rejecting other common timebases:

- MJD is subject to leap seconds making the fractional portion very hard to represent in a fixed-point format.
- UTC is subject to leap seconds making the number of seconds in a day variable (86 399 / 86 400 / 86 401).
- GPS Time is subject to 'week number wrapping' approximately every 19,7 years.
- UTC, TAI, MJD and GPS Time all have epochs (start dates) partway through the 400-year leap-year cycle.

The DVB-T2 Timestamp is not subject to leap seconds but contains sufficient extra information (in the $utco$ field) to trivially convert the value to UTC which does include leap-seconds. Conversion to GPS Time and/or TAI is also trivial, simply involving the subtraction of a constant value. The epoch for DVB-T2 Time is synchronized with the start of a 400-year leap-year cycle, making leap-year calculations simpler and less error prone.

History

This clause shall be the last one in the document.

History box entries

Document history		
<Version>	<Date>	<Milestone>