

DVB-T2

Call for Technologies

Summary

The DVB Project is requesting the submission of technologies which could be considered as candidates for a second generation terrestrial transmission system. This call for technologies follows the work done by the earlier DVB Technical Module study mission and is issued to meet the commercial requirements prepared by the DVB Commercial Module. Responses are requested by 04 June 2007.

1 Introduction

In 2006 a study mission of the DVB Technical Module (TM) produced a report identifying some possible technologies that could be considered for providing enhancements to the existing DVB-T standard [ETSI EN 300 744]. Following this, the DVB Commercial Module (CM) was requested to consider and to develop, if appropriate, commercial requirements for enhanced services for the terrestrial platform. As a result an ad-hoc group CM-AMT (advance modulation for terrestrial) was formed, and this developed commercial requirements. These are available in condensed tabular form in Annex 1.

One of the issues identified was that one early application of any DVB-T2 specification would be for HDTV broadcasting, and that the timescale for this was relatively short. It was therefore agreed that an ad-hoc group TM-T2 would be formed to work in parallel with the CM-AMT group to continue the work started by the study mission, and to analyse in detail potential technologies, and this has taken place.

Three phases of work have been identified :

- a first phase of work aimed primarily at fixed receivers using existing aerials and down-leads, and portable receivers
- a second phase of work that offers higher payloads from a given amount of spectrum, but not necessarily using existing aerial installations
- a third phase of work aimed at mobile reception

The first goal of this CfT is to address phase 1, however there may be merit also to consider responses which deal with the first two phases..

Whilst not directly addressing the third (mobile) phase, DVB would nonetheless be interested in responses which indicated how a proposal might be extended to cover the later mobile phase, in a way which maximised compatibility between the phases.

In addition to formal proposals targeting a draft specification in response to this CfT, DVB would also be interested to receive responses which take a form more appropriate for 'engineering guidelines'.

The Call is open for responses to DVB Members, as well as to non-members who would be asked to join DVB.

Evaluation of responses will follow and it is anticipated that a draft standard will be available for phase 1 early in 2008.

2 Areas in which contributions are requested

Responses to this Call for Technologies are requested in the areas identified in this section. However it should be noted that responses need not be limited to the specific techniques identified – indeed DVB would be keen to receive responses which meet the commercial requirements, but which are outside the initial list of techniques given below.

As well as responses addressing individual technology elements, DVB is also interested in responses that contain whole system proposals.

Respondents should note that, to maintain maximum compatibility with the family of DVB standards, the working assumption has been made that exactly the LDPC forward error correction code from DVB-S2 will be used, and so proposals are sought which fit this to the terrestrial physical layer. Whilst responses may be submitted based around other channel coding techniques, these will only be considered if it is determined that the DVB-S2 LDPC code is not suitable for the terrestrial channel, or would impose unwanted restrictions on the system design, selection of other technologies and system parameters (e.g. frame structure) appropriate for DVB-T2.

Modulation and coding

- multi-carrier/single carrier
- alternative approaches to channel equalization
- alternative approaches to synchronisation
- ...

Channel Coding

- DVB-S2 LDPC code and other coding schemes (see comments above)
- Extensions of a phase 1 system to include MIMO and/or diversity systems
- Time interleaving
- ...

Signal pre-conditioning

- Flexible multiplexing
- Variable coding and modulation
- Burst transmission
- PAPR reduction
- ...

3 Assessment of responses

No specific decisions have yet been made about how responses will be assessed – it is not yet possible to foresee all possible criteria before responses have been received. However, where possible we will try to achieve consensus about the final choice of technologies.

DVB will take decisions largely on technical performance. This will include considering how technology elements from different proposals fit with each other. Other factors may also be taken into consideration, e.g. complexity, power consumption and time to market.

Respondents should note that the commercial requirements are prioritised by means of the terms 'shall', 'should' and 'may'. In deciding between technologies, DVB will aim to consider responses which address these requirements in this order of priority – i.e. requirements containing 'shall' will be considered first.

4 Formalities

4.1 General terms and conditions

DVB will not consider submissions that contain detail that is confidential. Those submitting information acknowledge that any and all information contained in their submission will *not* be treated as confidential and should not be marked as such. However, access to any software delivered as part of a response to this CfT will be restricted to those actively involved in the T2 assessment/ development work.

Receipt of submissions does not imply that the information will be included in any DVB specification.

4.2 Submission Details

The responses to this Call should be submitted by email before the appropriate deadline to the DVB project office: gianetti@dvb.org with a copy to the chairperson of the DVB TM-T2 ad-hoc group nick.wells@rd.bbc.co.uk. Documents should be attached in one of the following formats: MS-Word, HTML or PDF.

Due date and time: Monday 04/06/2007 before 12:00 UTC

4.3 Format of the proposal

In order to speed up the evaluation of the submitted papers, proposers are requested to use the format described below. It should be noted that proposals may be received which do not fully meet this format, or which do not include the full details requested. However priority may be given to those proposals which are more completely described according to this format.

Whilst DVB is keen to receive responses concerning any technology element, it is also keen to receive responses that assemble combinations of elements into a whole system proposal.

As mentioned previously, the first goal of this call mainly relates to the first phase of work: for fixed/portable reception with an existing receiving installation. However, it would be beneficial for respondents to show clearly how their proposal could be adapted in the future to cover the areas expected to be addressed by the second and third phases.

Suggested format

Table of Contents

- Contact details
- Executive summary
- IPR statement
- Functional areas addressed
- Description of the technology
- Simulation model/pseudo code
- Performance description
- etc...

Contact details for proposer

Individual contact name
Organisation
Telephone
Fax
Email
Postal address

Executive summary of the proposal

A brief description of the proposal, preferably in non-technical terms, should be provided. This should be less than 500 words.

Proposed Arrangement for launching T2 Pooling

One conclusion from DVB's recent experience with patent issues is that it is desirable to have an early completion of a pooling effort. This provides greater certainty to implementers and, while not ex ante, can lead to more timely disclosure of essential IPRs.

For T2, we would like to attempt to head off the risk of long delays in pool completion. For this reason, contributors to the T2 specification will be asked if they are willing to be contacted in respect of a pooling effort. This contact will be initiated soon after the responses to this CfT have been assessed.

Therefore, as part of this CfT, respondents are asked to indicate their willingness to participate in the initial steps of a pooling effort if they think that they have IP which is relevant or may become relevant to T2. Respondents are asked to complete Annex 3 as part of their response to this CfT.

Functional areas addressed

The proposals should describe which item(s) of the commercial requirements are addressed.

Description of the technology of the proposal

The proposals should include a detailed description, including a full block diagram or other relevant description. If the proposal consists of an entire system proposal, a block diagram of the system should be included. If the proposal consists only of modifications to certain blocks of the current DVB-T standard, it should be made clear which blocks of a current transmitter and receiver would need to be modified. This should be done by reference to the generic block diagram of a DVB-T transmitter and receiver which is included as Annex 2 to this CfT.

Simulation results / software model

Before a particular technology can be adopted, it is likely that an independently verifiable software simulation model will need to be developed. Respondents are therefore encouraged to deliver, together with their proposal, as much as possible of the following:

- results of their own simulations demonstrating the benefit of their proposal
- sufficiently detailed description of the proposal to allow a software simulation model to be built
- a software model incorporating their proposal, which would allow independent verification of the proposers simulation results. If at all possible, the software model should take the form of Matlab, Ansi C modules which can be incorporated into the simulation model defined by the T2 Simulation Model Workgroup.

In view of the relatively short timescale for responding to the CfT, it would be acceptable for proposals to be delivered which initially contained only a description of the basic technology being proposed. In this case, respondents should indicate their willingness to deliver the further details indicated above and propose the date when this will be completed, and/or indicate their willingness to work within the DVB TM-T2 ad-hoc group to develop a suitable simulation model. Respondents should not assume that others within the DVB TM-T2 ad-hoc group will do this work for them.

For modules of the software model representing the transmitter, full source code in C, C++ or Matlab will be required. It is preferred that these will be compatible with the simulation model defined by the T2 Simulation Model Workgroup.

If the proposal relates to a receiver, or requires modifications to a conventional DVB-T receiver, it is accepted that the proposer's know-how might be contained in their software implementation. In this case it would be acceptable to fully describe the required interface, but for the details of the software module to be encrypted, thereby allowing its operation to be verified without disclosing the detailed operation. However, as a minimum, proponents should provide convincing theoretical explanation of the achievable performance. It should be noted that, before a technology can be included in the final standard, it must be demonstrated that more than one implementation is commercially practicable. It would also help in adopting any technique if as much as possible could be revealed (except the final details of the implementation). Verification of the claimed performance may be requested.

Compatibility with existing aerial installations

Respondents are reminded of the following points extracted from the commercial requirements. Commercial requirement no. 21 states: "The DVB-T2 specified signal shall be able to be received using existing DVB-T domestic antenna and cable installations."

Furthermore, the introduction to the commercial requirements states:

"A general policy of these requirements thus has been to call for high level of compatibility with the existing DVB-T infrastructure including both transmission and domestic reception installations, to facilitate the migration from DVB-T.

Compatibility requirements may rule out the most significant performance improvements that could be gained by introducing non-backwards compatible, disruptive state-of-the art, yet rapidly maturing technologies. It is planned that such technologies will be considered during future phases of DVB work."

Performance description

The proposals should/could be backed up with information how the system performance relative to DVB-T is changed by applying the technology. Some proposals may not be described directly as performance figures. Then other appropriate ways of describing the benefits should be used.

Complexity, and other commercial requirements

The proposals should have an estimate of the complexity when compared to the present DVB-T system. Specifically the feasibility to implement such proposal in the CR's requested timescales should be addressed. Also special influence on any commercial requirement should be discussed, for example the requirement that proposals should target a significant increase in the DVB-T bitrate using existing domestic antenna and cable installations.

Other information in support of your proposal

Please use this section to describe any special features of your proposal not covered by the above sections

Annex 1: List of Commercial Requirements

N°	Requirement
1	The DVB-T2 specification shall be designed for stationary reception. However, it shall be possible to design DVB-T2 networks for all three receiving conditions, fixed, portable and mobile.
2	Transmissions using the DVB-T2 specification shall meet the interference levels and spectrum mask requirements as defined by GE06 and not cause more interference than DVB-T would do.
3	The DVB-T2 specification should target the maximum increase in net payload capacity over DVB-T with similar or better robustness than DVB-T under similar conditions.
4	The DVB-T2 specification shall provide a minimum increase in net payload capacity of 30% greater than DVB-T for any given channel profile under similar conditions.
5	The characteristics of the DVB-T2 specification shall not impair the ability to perform, or efficiency of, statistical multiplexing of DTV Services.
6	The DVB-T2 specification should offer improved robustness against interference from other transmitters, compared to DVB-T, potentially improving frequency reuse.
7	The DVB-T2 specification shall offer a choice of various robustness and protection levels to be applied equally on all data of a transport stream carried by a DVB-T2 signal in a particular channel.
8	The DVB-T2 specification should offer a choice of various robustness and protection levels for each service separately, within a transport stream carried by a DVB-T2 signal in a particular channel. When more than one transport stream is carried by a DVB-T2 signal in a particular channel the DVB-T2 specification should offer a choice of various robustness and protection levels for each transport stream separately.
9	The DVB-T2 specification shall provide a quality of service across the whole channel that approximates to no more than one corrupted event (to any audio, video or data services) per hour for HDTV and SDTV services.
10	Impulsive noise performance of DVB-T2 shall be no worse than the DVB-T performance and should be substantially improved from that of DVB-T.

11	The DVB-T2 specification shall enable changes in modulation mode to be detected automatically within 0,5s. However, the receiver may not be capable of performing seamless changeover.
12	The DVB-T2 specification shall not introduce any more than 0,3s of additional delay in receiver channel changing and service selection times compared to DVB-T.
13	The DVB-T2 specification shall be able to provide at least the minimum specified increase in payload capacity over DVB-T using existing transmitter sites and masts broadcasting to existing DVB-T domestic antenna and cable installations.
14	The DVB-T2 specification should be designed to allow lower cost transmitters (in terms of both capital and operational costs) than currently for DVB-T (for a given output power).
15	The DVB-T2 specification should enable larger scale SFNs than currently possible with DVB-T. The maximum distance between adjacent transmitters in the same SFN should be at least 30% larger than that offered by a comparable DVB-T 8k mode for the same level of self-interference.
16	The DVB-T2 specification should enable the development of cheap and regulation-compliant home gap fillers to ease indoor coverage, for fixed, portable and mobile services.
17	The DVB-T2 specification shall provide for local, regional and national coverage areas in an economical way (i.e. optimising infrastructure costs and spectrum usage including SFN and/or MFN techniques) whilst also meeting spectrum management conditions and constraints as defined within the relevant international treaties and other agreements.
18	Any changes to the Service Information delivery caused by DVB-T2 specification shall be incorporated in the common DVB SI specifications.
19	The DVB-T2 specification shall support direct carriage of MPEG2 transport streams and shall be capable of carrying all DVB transports including MPEG2 and GSE.
20	The DVB-T2 specification shall support the carriage of multiple DVB transports simultaneously on a single channel.
21	The DVB-T2 specified signal shall be able to be received using existing DVB-T domestic antenna and cable installations.

Annex 2: Generic block diagram of DVB-T transmitter and receiver

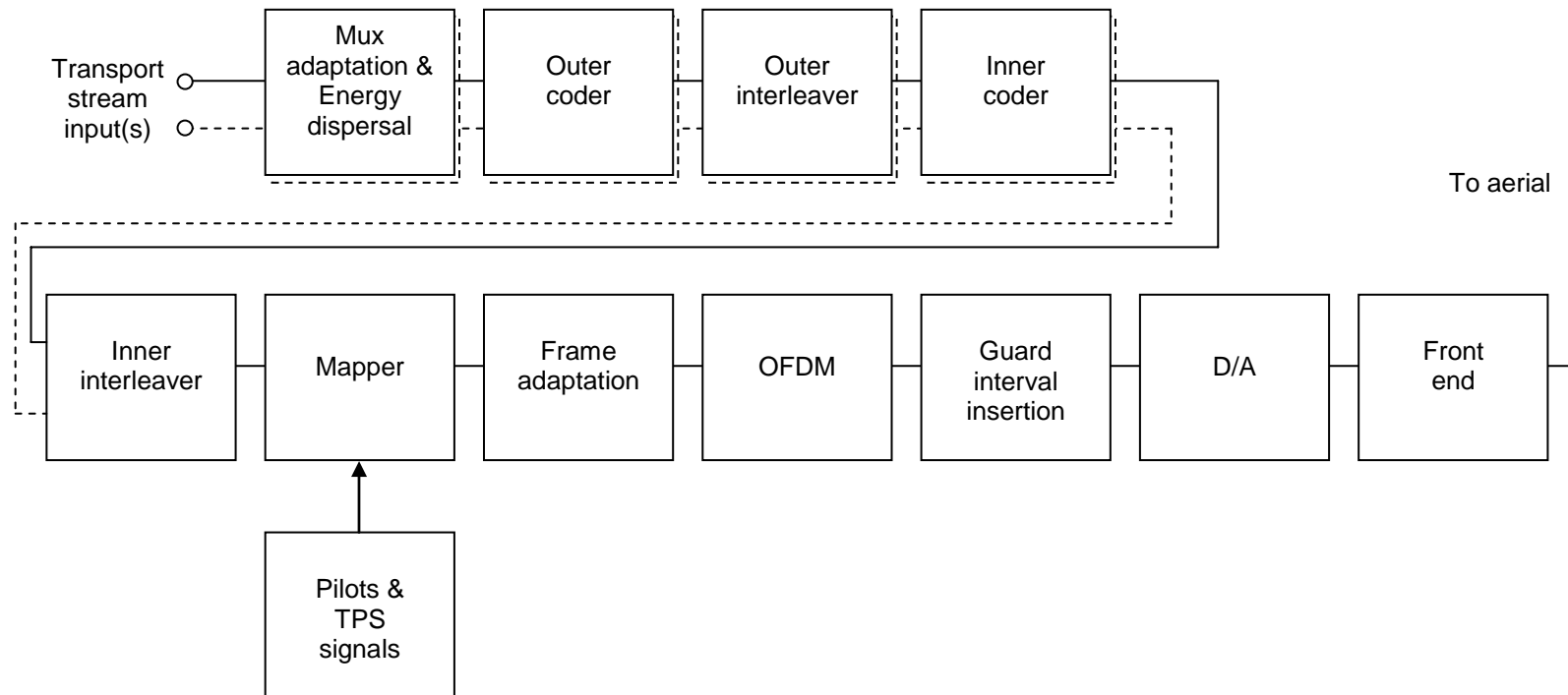

Figure 1 Generic block diagram of DVB-T transmitter

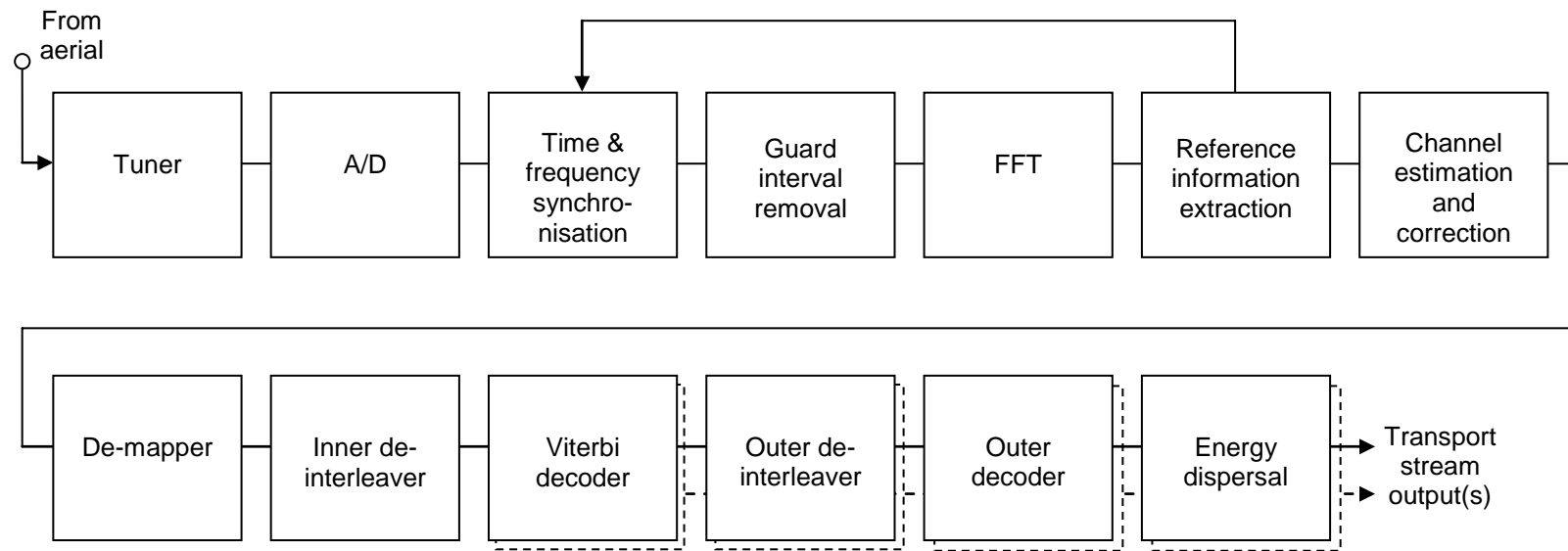

Figure 2 Generic block diagram of DVB-T receiver

Annex 3: IPR

Respondents are requested to provide the following information:

/_/ DVB fosters the formation of voluntary licensing programmes.

DVB intends to begin its fostering process early in the work of the T2 specification. It is contemplated that a meeting will be held of lawyers and licensing specialists of contributors on the fringes of a future T2 meeting in 2007. Please indicate whether you would like to be notified about this meeting by the Legal Director DVB, eltzroth@dvb.org and to receiving further information on the pooling effort.

If so, please indicate the name and email address of your representation to this pooling discussion meeting.

(name of IPR specialist)

(email address)

Note: the meeting is intended for T2 participants that have a well-founded belief that they may hold IPRs essential to the T2 specification, including in the form of patents and patent applications.

The Legal Director DVB will call an initial meeting to occur alongside a meeting of T2. The agenda of this first meeting would identify tasks and set a schedule for the work of this Pool Planning Group. The ambition would be to announce a pool shortly after the technical work on T2 is completed. The pool would be comprised initially of holders of issued patents and would grow as further patents are granted. It is intended that this initial pool will follow guidelines developed as part of the requirements developed by the Pool Planning Group